



Regular Village Board Meeting Agenda

April 18, 2023 – 6:00 pm
Village Hall, 235 Hickory Street, Pewaukee, WI 53072

To view the meeting live: <https://youtube.com/live/JYSv-zJWUx0?feature=share>

1. Call to Order, Pledge of Allegiance, Moment of Silence and Roll Call.
2. Public Hearings/Presentations. – None.
3. Approval of Minutes of Previous Meeting.
 - Minutes of the Regular Village Board Meeting – April 5, 2023
4. Citizen Comments. – *This is an opportunity for citizens to share their opinions with Board Members on any topic they choose. However, due to Wisconsin Open Meeting laws, the Board is not able to answer questions or respond to your comments. All comments should be directed to the Board. Comments are limited to 3 minutes per speaker. Speakers are asked to use the podium and state their name and address.*
5. Ordinances.
 - a. Possible Action on Ordinance No. 2023-04, Ordinance to Amend Chapter 14, Article VI, Section 14.243 of the Village of Pewaukee Code of Ordinances Regarding Demolition of Buildings
6. Resolutions.
 - a. Resolution No. 2023-04, Resolution Recognizing the Service of Edmund Hill to the Village of Pewaukee
7. Old Business. – None.
8. New Business.
 - a. Discussion and Direction on Trustee Committee Appointment Terms
 - b. Discussion and Direction on Email Newsletter Options
 - c. Discussion and Update on Quiet Zone Process
 - d. Discussion and Direction on Oakton Avenue Sealed Corridor Project
 - e. Discussion and Possible Action on raSmith Agreement Regarding Kiwanis Village Park Sanitary Sewer Lateral Design and Bid Document
 - f. Discussion and Possible Action on Committee Appointments
 1. Board of Review – 2 Regular Members and 1 Alternate Member (all 3 year terms)
 2. Plan Commission – 1 Trustee
 3. Public Works & Safety Committee – 3 Members (2 year terms); 2 Trustees
 4. Zoning Board of Appeals – 2 Members (full 3 year terms); 1 Alternate (term to expire 4/30/24); 1 Alternate (3 year term)
 4. Park & Recreation Board – 2 Members (3 year terms); 1 Trustee (3-year term)
 5. Police Commission – 1 Member (3 year term); 1 Member (term ending 4/30/24)
 6. Sex Offender Residency Appeal Board – 2 Members (3 year terms)
 7. Historic Preservation Commission – 1 Member (term to expire 4/30/24); 1 Member Architect (term to expire 4/30/24); 1 Member (3 year term)
 8. Lake Advisory Committee – 1 Trustee
 9. Joint Library Board – 1 Member
 - g. Review of Quarterly Financial Reports and Monthly Approval of Checks and Invoices for all funds – March 2023



Regular Village Board Meeting Agenda

9. Citizen Comments. – *This is an opportunity for citizens to share their opinions with Board Members on any topic they choose. However, due to Wisconsin Open Meeting laws, the Board is not able to answer questions or respond to your comments. All comments should be directed to the Board. Comments are limited to 3 minutes per speaker. Speakers are asked to use the podium and state their name and address.*
10. Closed Session. – The Village Board of the Village of Pewaukee will enter into closed session pursuant to Wis. Statute Section 19.85(1)(e) for the purpose of deliberating or negotiating the purchasing of public properties, the investing of public funds, or conducting other specified public business, whenever competitive or bargaining reasons require a closed session, specifically regarding Joint Library Agreement with City of Pewaukee.
11. Reconvene Into Open Session.
12. Adjournment.

Note: Notice is hereby given that a quorum of a Village Committee and/or Commission may be present at the Village Board meeting, and if so, this meeting shall be considered an informational meeting of that Committee or Commission and no formal action of that Committee or Commission shall occur. Upon reasonable notice, efforts will be made to accommodate the needs of disabled individuals through appropriate aids and services. To request such assistance, contact the Village Clerk at 262-691-5660.

Posted April 14, 2023

**VILLAGE OF PEWAUKEE
VILLAGE BOARD MINUTES
April 5, 2023**

1. Call to Order, Pledge of Allegiance, Moment of Silence, and Roll Call

President Knutson called the meeting to order at approximately 6:00 p.m. The Pledge of Allegiance was recited, followed by a moment of silence.

Roll Call was taken with the following Village Board members present: Trustee Ed Hill, Trustee Bob Rohde, Trustee Kelli Belt, Trustee Chris Krasovich, Trustee Jim Grabowski; Trustee Craig Roberts; and President Jeff Knutson.

Also Present: Village Attorney, Mark Blum; Director of the Public Works Department, Dan Naze; Village Administrator, Scott Gosse; Village Clerk, Cassie Smith; and Chief of Police, Tim Heier.

2. Public Hearings/Presentations

- a. Ordinance No. 2023-02, Ordinance to Amend Section 40.471 of the Village Code of Village of Pewaukee Regarding the Regulation of Transient Commercial Lodging Uses in Residential Districts**

No comments were made.

3. Approval of Minutes of Previous Meeting

- a. Minutes of the Regular Village Board Meeting – March 21, 2023**

Trustee Hill moved, seconded by Trustee Krasovich to approve the March 21, 2023, minutes of the Regular Village Board meeting as presented.

Motion carried 7-0.

4. Citizen Comments

Steve Rucci @ 161 W Wisconsin Ave. – Mr. Rucci spoke regarding the Village’s Liquor Licenses and asked for a waiting list to be created.

Sarah Stephens @ 161 W Wisconsin Ave - Ms. Stephens spoke about renting the two public parking spots outside her business. She asked for the same consideration as other businesses that rent spots for street dining so that she can have dedicated spots for her customers to pick up from her store.

5. Ordinances

- a. Possible Action on Ordinance No. 2023-02, Ordinance to Amend Section 40.471 of the Village Code of Village of Pewaukee Regarding the Regulation of Transient Commercial Lodging Uses in Residential Districts**

Administrator Gosse stated that this Ordinance was discussed at the Plan Commission for several months. The Plan Commission recommended the current code language to the Village Board on a 4-2 vote. The current code language is not compliant with State Statutes and the draft language would bring the code into compliance. The Plan Commission recommended a 3-night minimum, with rentals allowed 365 days per year, and an annual license.

Trustee Roberts stated this item was on the Plan Commission agenda for 3 months, and an agreement couldn’t be met. The proposed draft language was recommended to the Village Board with a 4-2 vote which demonstrates it

is not overall favored. State Statutes prevail until we have an ordinance that is compliant. The minimum stay can be 1-6 nights and we could place a limit on rentals from 180 – 365 days. Roberts stated he is opposed to the minimum night stay of 3 nights. He would like to ensure that rentals are not bachelor or bachelorette parties which would create a nuisance for neighbors, and he is concerned that the land use is not compatible with the surrounding area. He believes short-term rentals do not fit in with the neighborhood, businesses should not be able to operate within residential areas. He would be in favor of the minimum allowed nights at 6 nights.

Trustee Grabowski stated that the short-term rentals have already been operating in the Village and according to the Police Chief, no complaints have been made at these properties. This could also create another revenue stream if we collected occupancy tax which the Village currently loses each year. This money could help pay for events such as fireworks. There is a lot of speculation, but the evidence of issues is lacking.

Trustee Rohde asked for insight on how the Plan Commission arrived at the 3-night minimum. Roberts responded and stated that there were many differences of opinion and 4-6 days would be more of a family-oriented stay instead of a party on the weekend. Rohde stated that a mechanism to address compliance issues will be complicated and he would rather avoid the problems rather than react to them.

Trustee Hill stated that four emails were received by the Board from Melissa and Mark Schieble, Amanda Wegner, and Kimberly Hanan; all four individuals expressed their opposition to the ordinance and want restrictions to be as restrictive as possible. The City of Pewaukee and Town of Delafield adopted an ordinance regarding short-term rentals and they have a minimum stay of 6 nights. The draft ordinance speaks to requiring a minimum of 3 parking stalls which relates to the requirements within the current code.

Trustee Grabowski stated that the Village Board hasn't heard of any residents who live next to a short-term rental. His residence is close to a short-term rental, and it has been a great experience.

Trustee Belt agrees with Trustee Roberts. She supports the most restrictive terms. Short-term rentals are more prevalent on the lake. Residential areas should stay residential, and lodging is better suited in a commercial area, not in a residential area. She expressed concerns about future ownership of these properties due to the trend of corporations buying homes. Managers living within 5 miles are not local owners. This area is not a tourist town and she would like it to stay a residential lake community.

Trustee Krasovich stated that it is obvious that there is not a consensus among the residents therefore whichever way the Board votes someone will not be satisfied.

Trustee Rohde expressed that he is concerned that Kopmeier Dr, which will have a 6-night minimum on one side of the Road and a 3-night minimum on the other. He believes we should not be completely different on the same road and that property owners have the right to know their next-door neighbors.

Trustee Grabowski stated that there is no correlation between short-term renters and criminal activity so this is a moot point. Long-term renters are harder to remove than short-term renters.

President Knutson stated that the Town of Delafield and the City of Pewaukee have hotels in their community, but the Village does not. The draft ordinance requires licensing which gives the Village the ability to investigate or withhold a license if a property becomes problematic. He stated that the Village doesn't have to follow what other communities do. He would like the Village to be a destination for people to come to and enjoy therefore he is in favor of the 3-night minimum.

Trustee Grabowski moved, seconded by Trustee Krasovich to Approve Ordinance No. 2023-02 to Amend Section 40.471 of the Village Code of Village of Pewaukee Regarding the Regulation of Transient Commercial Lodging Uses in Residential Districts with the Update in Section 6(1)(e) to Reference ATCP 72.

Motion carried on roll call vote 4-3; Trustee Rohde, Belt and Roberts voted nay.

b. Possible Action on Ordinance No. 2023-03, Ordinance to Amend Chapter 86, Article III, Section 86.111 of the Code of Ordinances Regarding Speed Limits Decreased (W. Wisconsin Avenue along Lakefront Park)

Trustee Hill explained that this Ordinance was presented at the Public Works and Safety meeting on March 21st, 2023. This ordinance would change the speed limit to 15 mph year-round. Trustee Hill responded to Trustee Rohde; the Commission felt that the same issues were present in the winter months regarding blind-angled

parking and pedestrians crossing out of the crosswalks.

Trustee Krasovich moved, seconded by Trustee Roberts to Approve Ordinance No. 2023-03 to Amend Chapter 86, Article III, Section 86.111 of the Code of Ordinances Regarding Speed Limits Decreased (W. Wisconsin Avenue along Lakefront Park) as Presented.

Motion carried 7-0.

6. Resolutions– None

7. Old Business - None

8. New Business

a. Discussion and Possible Action on Right-of-Way/Lease Agreement for Public Parking Spaces with Beach Bum Bakery, 161 W. Wisconsin Avenue, Unit 1G

Admin Gosse explained that Beach Bum Bakery submitted a request that was reviewed at the Public Works and Safety meeting on March 21st, 2023 which leases 2 parking spaces in front of the business for their customers only. The owner would like to rent the spaces from the Village just as other businesses do for dining. If approved the same terms and conditions as street dining rentals would be given. Gosse expressed that staff has discussed and enforcement is a concern due to the investigation time required if towing were to be utilized as a tool. Trustee Grabowski questioned the lease, if it is private could the rights be given to the leaser to enforce the parking? Attorney Blum spoke regarding the lease and stated that would be a policy decision but he would advise against allowing the business to tow vehicles at their discretion. Discussion followed regarding making 4 stalls 15-minute parking for all businesses and enforcement.

Trustee Krasovich moved, seconded by Trustee Grabowski to Approve the Right-of-Way/Lease Agreement for Public Parking Spaces with Beach Bum Bakery, 161 W. Wisconsin Avenue, Unit 1G as Presented.

Motion carried 6-1; Trustee Belt voting nay.

a. Discussion and Possible Action on Agreement with Flock Group Inc. for Hardware and Software License Plate Camera System

Admin Gosse stated that five Flock cameras cost \$15,000 for two years. The installation cost is \$1,750. The funds for the Flock cameras were approved using ARPA funds in the amount of \$15,000 but the cost of installation was omitted as the Department was not advised of the cost. Utilizing the operational budget to fund the installation can be done due to short staffing in the Police Department. This is a minimum 2 year agreement. Trustee Rohde stated that it is important to give the Police Department the best possible equipment to keep the community safe. Installation should begin within 6-9 weeks.

Trustee Hill moved, seconded by Trustee Rohde to Approve the Agreement with Flock Group Inc. for Hardware and Software License Plate Camera System in the Amount of \$15,000 Using ARPA Funds and an Additional \$1,750 for Installation Using the Operational Budget.

Motion carried 7-0.

a. Update on Finance Committee

Trustee Belt stated that she and Trustee Roberts met a few times to start framing the Finance Committee. The group has determined that a quarterly report will be presented at the second meeting of the month after the close of the quarter with Trustees Belt and Roberts reviewing monthly reports. Roberts stated that this will satisfy the strategic planning objective to create transparency of the Village’s finances. Belt stated that the Financial Dashboard has a goal to be completed by the end of September.

b. Discussion and Direction on Trustee Committee Appointment Terms

President Knutson asked for this item to be removed from this meeting.

c. Discussion and Direction on Proposed Building Code Amendment

Trustee Hill stated he would like to amend the Village ordinance regarding demolition. He would like the following to be added to the Ordinance language. “all hazardous and environmentally sensitive materials must be removed, contained and/or properly disposed of per current US EPA and WI DNR regulations with proper documentation submitted to Building Inspection Services. This includes and is not limited to; asbestos, lead based paint, florescent light bulbs, ballast, oil, and refrigerant.” The consensus of the Village Board is to bring this item back with the proposed language in Ordinance form.

d. Discussion and Possible Action on Proposal for Engineering Services, Village Bridge Deck Surface Treatments

Director Naze stated it was recommended to have a polymer overlay to extend the life of bridge decks. Ayres quoted a total cost of \$15,800. This amount is in the Capital Improvement Projects and the funds would be paid out of the Capital Project Fund.

Trustee Hill moved, seconded by Trustee Grabowski to Approve the Proposal for Engineering Services in the Amount not to Exceed \$15,800 for Bridge Desk Surface Treatments.
Motion carried 7-0.

a. Alcohol License

1. Possible Action on Agent Change at Pick-n-Save

Trustee Grabowski moved, seconded by Trustee Rohde, to Approve Craig Petersburs as the New Agent for Mega Marts, LLC Located at 1405 Capitol Drive.
Motion carried 7-0.

2. Possible Action on New Class A License Regarding 1256 Capitol Dr #600

The applicant requested to remove this item from the agenda.

9. Citizen Comments

Steve Rucci @ 161 W Wisconsin Ave. – Mr. Rucci requested the Village make a waiting list for a “Class B” license available online.

10. Closed Session. – *The Village Board of the Village of Pewaukee will enter into closed session pursuant to Wis. Statute Section 19.85(1)(e) for the purpose of deliberating or negotiating the purchasing of public properties, the investing of public funds, or conducting other specified public business, whenever competitive or bargaining reasons require a closed session, specifically regarding Riverside Preserve Developers Agreement; and pursuant to Wis. Statute Section 19.85(1)(g) for the purpose of conferring with legal counsel for the governmental body who is rendering oral or written advice concerning strategy to be adopted by the body with respect to litigation in which it is or is likely to become involved, specifically regarding 460 Park Avenue.*

Trustee Rohde moved, seconded by Trustee Hill to move into Closed Session at approximately 7:40 p.m.
Motion carried on Roll Call vote, 7-0.

11. Reconvene into Open Session

Trustee Grabowski moved, seconded by Trustee Roberts to reconvene into Open Session at Approximately 7:54 p.m.
Motion carried on Roll Call vote, 7-0.

a. Possible Action on Riverside Preserve Developers Agreement

Trustee Hill moved, seconded by Trustee Roberts to Approve the Riverside Preserve Developers Agreement as Presented with the Addition of Requiring the Developers Agreement be Signed and Returned Before April 14, 2023.

Motion carried 7-0.

b. Possible Action on Proposal Related to 460 Park Avenue Regarding Property Maintenance
Trustee Roberts moved, seconded by Trustee Grabowski to Engage in an Agreement with Facility Services Group to Clean the Yard, Remove Hazardous Materials from the Property, and Secure the Doors and Windows.
Motion carried 7-0.

12. Adjournment

Trustee Hill moved, seconded by Trustee Krasovich to adjourn the April 5, 2023, Regular Village Board meeting at approximately 7:57 p.m.
Motion carried 7-0.

Respectfully Submitted,

Casandra Smith
Village Clerk

DRAFT



To: Jeff Knutson, President
Village Board

From: Scott A. Gosse
Village Administrator

Date: April 13, 2023

Re: Agenda Item 5a, Ordinance No. 2023-04, Ordinance to Amend Chapter 14, Article VI, Section 14.243 of the Village of Pewaukee Code of Ordinances Regarding Demolition of Buildings

BACKGROUND

This matter was on the last Village Board agenda for review and direction on amending the building code to add the underlined text in the attached draft ordinance. This matter is returning to the Village Board agenda for possible action on the requested changes.

ACTION REQUESTED

The action requested of the Village Board is to consider adoption of Ordinance No. 2023-04, Ordinance to Amend Chapter 14, Article VI, Section 14.243 of the Village of Pewaukee Code of Ordinances Regarding Demolition of Buildings.

Attachment

ORDINANCE NO. 2023-04**Ordinance to Amend Chapter 14, Article VI, Section 14.243 of the Village of Pewaukee Code of Ordinances Regarding Demolition of Buildings**

SECTION I

WHEREAS the Village Board of the Village of Pewaukee desires to clarify requirements for the issuance of demolition and raze permits for buildings or structures proposed to be demolished or razed.

SECTION II

NOW, THEREFORE, the Village Board does hereby ordain to amend create Section 14.243, Demolition of Buildings, to read as follows:

Sec. 14.243. Demolition of buildings.

Before a building can be demolished or removed, the owner or agent shall notify all utilities having service connections within the building such as water, electricity, gas, sewer and other connections and those connections shall be capped and terminated in accordance with the rules of the respective utilities. ~~In addition;~~addition, all hazardous and environmentally sensitive materials must be removed, contained and/or properly disposed of per current US EPA and WI DNR regulations with proper documentation submitted to Building Inspection Services evidencing that the materials have been removed and appropriately disposed of. ~~This includes and is not limited to; asbestos, lead based paint, fluorescent light bulbs, ballasts, oil, refrigerant.~~ A permit to demolish or to remove a building shall not be issued until it is ascertained that service connections and appurtenant equipment, such as meters and regulators, have been removed or sealed and plugged in a safe manner. Excavations shall be filled with solid fill to match lot grade, within 30 days of removal of the structure. Any excavation shall be protected with appropriate fences, barriers and/or lights. Before the demolition of a landmark, landmark site or improvement within an historic district the applicant must comply with Section 40.482 of the Village Code of Ordinances.

SECTION III

All ordinances or parts of ordinances contravening the terms and conditions of this ordinance are hereby to that extent repealed.

SECTION IV

The several sections of this ordinance shall be considered severable. If any section shall be considered by a court of competent jurisdiction to be invalid, such decision shall not affect the validity of the other portions of the ordinance.

SECTION V

This ordinance shall take effect upon passage and publication or posting as approved by law, and the Village Clerk shall so amend the Code of Ordinances of the Village of Pewaukee, and shall indicate the date and number of this amending ordinance therein.

Passed and adopted this _____ day of _____ 2023 by the Village Board of the Village of Pewaukee.

APPROVED:

Jeffrey Knutson, Village President

Countersigned:

DRAFT

RESOLUTION NO. 2023-04

**A Resolution Recognizing the Service of
Edmund Hill
to the Village of Pewaukee**

WHEREAS, Ed Hill was elected as a Village Trustee in April 2017 and was re-elected to three additional two-year terms until finishing his last term in April 2023; and

WHEREAS, Ed Hill was appointed to serve on the Pewaukee Lake Advisory Board 2019-2023; and

WHEREAS, Ed Hill was appointed to serve on the Public Works and Safety Committee in 2017 where he is currently serving; and

WHEREAS, Ed Hill assisted in serving as an Election Inspector 2020-2021; and

WHEREAS, Ed Hill assisted in the development of the Department of Public Works Building plan using his expertise in facilities management; and

WHEREAS, Ed Hill used his expertise to help develop a 10 year capital improvement plan with an emphasis on building maintenance needs; and

NOW, THEREFORE, BE IT RESOLVED by the Village Board of the Village of Pewaukee, Waukesha County, Wisconsin, that it hereby extends its heartfelt appreciation for the dedication given to the Village of Pewaukee by Ed Hill while serving the residents of the Village as a Village Trustee.

Dated and approved this 18th day of April 2023.

Approved:

Jeffrey Knutson, Village President

Certified:

Cassie Smith, Village Clerk



To: Jeff Knutson, President
Village Board

From: Scott A. Gosse
Village Administrator

Date: March 29, 2023

Re: Agenda Item 8a, Discussion and Direction on Trustee Committee Appointment Terms

BACKGROUND

This matter is on the agenda at the request of Village President Knutson. President Knutson has asked to have a discussion with the Village Board on whether the Village Code should be changed as it relates to the terms for Trustees appointed to committees so that a Trustee remains appointed to a committee for the duration of their term versus the current code requirement for most committees where appointments are for one-year terms requiring a reappointment by the Village President to remain on the committee.

ACTION REQUESTED

This matter is on the agenda for discussion and direction.

ANALYSIS

Attached for your review please find copies of the Village Code as it relates to the following committee memberships for Trustees:

1. Joint Library Board
2. Joint Park & Recreation Board
3. Plan Commission
4. Public Works & Safety Commission

Attachments



To: Jeff Knutson, Village President
Village Board

From: Cassie Smith
Village Clerk

Date: April 14, 2023

Re: Agenda Item 8b, Discussion, Direction, and/or Possible Action on Newsletter Delivery Options

BACKGROUND

On March 7th the Village Board gave direction to continue to seek options available to push out information to residents. In brainstorming the different ways to feed information to residents we began to research newsletter options which lead to a few different options such as thinking “big picture” to have a solution that will be long-lasting.

Demographics

Regarding the Village’s demographics it was discovered that 21% of Village residents are under 18 years and 23% of residents are over 65 years. This would determine that roughly 75% of our residents are probably familiar with texting, emailing, and apps. I have been working with Positively Pewaukee and Trustee Krasovich to get advice on different options.

Analytics

Attached you will see a chart that shows the unique page views for 2022. Unique pageviews combine the pageviews that are from the same person, on the same page, in the same session, and just count them as one. Unique pageviews are tracked for each page URL and page title combination. A user could view the same page 15 times, and refresh it multiple times as well—but if all of the views come in one session, it only counts as one unique pageview. This is helpful to view what residents are searching for on the website. The most searched item was the recycling center in 2022 which is 361 clicks on average per month.

NEWSLETTER OPTIONS

Constant Contact - Newsletter

The quote includes a setup to create and push out Important Info/Reminders to subscribers. This would be helpful for certain Village events such as elections, hydrant flushing, yard waste hours, etc. The annual cost of the newsletter program is driven by the number of subscribers (shown below), therefore as the subscriber lists continue to grow so does the cost. The library subscribed to this service in the past but many emails ended up in spam mailboxes. Prices are related to the number of subscribers.

The ability to place the newsletter on our website requires an upgraded subscription of \$5.00 per month or an extra \$60 per year. The estimated cost for the first year is roughly \$425 - \$1,320. \$10-\$80 per month with up to 10,000 subscribers.

TEXT MESSAGE OPTION

American Marketing & Publishing

Text messages may be used to reach a larger audience; most people young and old use cell phones and are familiar with texting. The vision for utilizing text messages would be to push out important information and notifications to residents. AMP has this option which enables a link to be embedded in the text message to direct the reader to that area on our website. Text messages have an average of 99% open/read rate. The cost is \$1,395 per year which gives us 150,000 text messages per year. After the 150,000 messages have been used the cost is \$0.015 per message. Each message means each message to each subscriber. If we had 5,000 subscribers' staff could send out 30 messages per year. Currently, we estimate we would send 14-18 messages at minimum, per year; 6 messages for DPW Important dates, 4-8 per year for elections, and 4 for a quarterly newsletter. The list of possibilities will grow with time. Once a subscriber decides to sign up they take a picture of a QR code or text a number. The company then sends a text with a link to the terms of use. In the terms, we would indicate the average number of text messages they may receive in a year while also including that if they sign up they may incur text charges.

COMBINATION OPTIONS

GoGov

Combining phone notifications/alerts and sending emails is an option with GoGov. This service would allow multiple means of communication. The subscriber would download a Village of Pewaukee-created app on their phone. The app, once opened, would contain information on frequently asked questions. The Village staff can send out a notification on the app and email subscribers. This service **doesn't** have a maximum number of messages in a month or year. The cost is \$3,900 per year. To view the recorded demo click the link and click around the 8:00 minute mark by clicking this link [GOGov / Pewaukee Village, WI – Notifications Demo](#).

CivicPlus

Integrated into our website, CivicPlus has a product that allows subscribers to sign up to receive emails and/or text message alerts which can also be sorted based on categories. The [City of Oconomowoc](#) utilizes this notification system through its website provider CivicPlus. Non-subscribers are able to view past notifications by category on the website. The admin portal allows staff to check the delivery, blocked, and opened messages. The initial setup which includes training costs \$938 (one-time fee). The annual fee is \$1,995 which includes unlimited emails and up to 500 text messages per month. To purchase additional text messages the cost is \$945 per 500 (purchased in blocks of 500). As subscribers continue to grow so will the price.

Sendinblue

This marketing platform is where you are able to track delivery rates, spam rates, and open rates with high detail. This platform sends emails and text messages to subscribers from an online site. This option

seems to be more geared for marketing, but you may [view the demo online](#). The cost is \$65 per month (\$780 annually) which allows us to send 20,000 emails per month and texting cost \$1.90 per 100 texts.

FACEBOOK

Page Freezer & Archive Social

Page Freezer and Archive Social are two Companies that archive and preserve media accounts which would allow the Village to satisfy the necessary requirements of the state’s open records law and would allow searching to satisfy open record requests. These services cost roughly \$1,200 per year plus a one-time training fee of \$250 for Page Freezer and \$4,200 per year fee for Archive Social. This solution would allow staff to utilize Facebook to present information to subscribers with the hope of reaching a majority of residents. Staff could place an embedded Facebook feed on our website for a cost of \$5-\$10 per month. There are two options for embedding Facebook; to view the options click the links below. [Option 1 - \\$5 per month](#) / [Option 2 - \\$10/month](#)

COMPANY	SETUP/ TRAINING	ANNUAL COST	VIEWED ON VOP WEBSITE	NEWS-LETTER	TEXTING	SOCIAL MEDIA	APP	NOTES
CONSTANT CONTACT	\$ 300.00	\$1,020.00	X	X				PRICE INCREASES WITH NUMBER OF SUBSCRIBERS
AMERICAN MARKETING		\$1,395.00			X			PRICE INCLUDES 150,000 MESSAGES PER YEAR AND EACH ADD'L IS \$0.015/MESSAGE
GOGO		\$3,900.00					X	UNLIMITED NOTIFICATIONS
CIVICPLUS	\$ 938.00	\$1,995.00	X	X	X			UNLIMITED EMAILS AND 500 TEXT MESSAGES
SENDINBLUE		\$ 780.00		X	X			PRICE INCLUDES 20,000 EMAILS BUT TEXTS ARE ADD'L AT \$1.90/100 TEXT MESSAGES
ARCHIVE SOCIAL		\$ 4,200.00	+\$5 - \$10/mo			X		ARCHIVES SOCIAL MEDIA SITES (CAN START DOING PD'S AS WELL)
Page Freezer	\$ 250.00	\$ 1,188.00	+\$5 - \$10/mo				X	ARCHIVES UP TO 2 SOCIAL MEDIA SITES (CAN START DOING PD'S AS WELL) ARCHIVES BACK TO IMPLEMENTATION.

Action Requested:

Staff seeks direction and/or possible action on options presented as to which direction the Village Board would like to take to deliver important information to residents.

Analysis:

With the data provided, it is my recommendation that we determine which type of service would be most advantageous to deliver necessary information to as many residents as possible. It is my recommendation that whichever tool is used we need to assess the options for growth and diversity in pushing out information, which should be a priority.

2022 Google Analytics - Unique Page Views







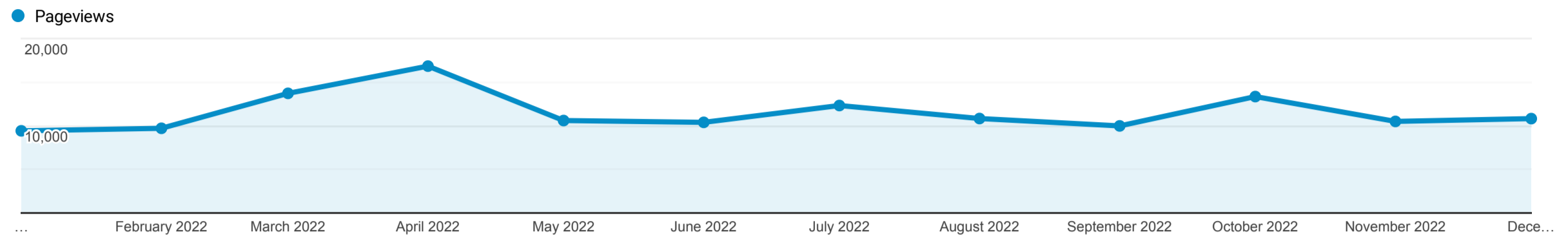

































Jan 1, 2022 - Dec 31, 2022

All Users
100.00% Pageviews







Explorer











































































Page	Pageviews	Unique Pageviews ↓	Avg. Time on Page	Entrances	Bounce Rate	% Exit	Page Value
Pageviews are defined as the total number of times the piece of content was viewed during a given period of time. Unique Pageviews represent an aggregate of pageviews generated by the same user during the same session (i.e. the number of sessions during which that page was viewed one or more times). The time limit for a given session is 24hrs.							
	138,087 % of Total: 100.00% (138,087)	104,961 % of Total: 100.00% (104,961)	00:01:08 Avg for View: 00:01:08 (0.00%)	56,183 % of Total: 100.00% (56,183)	57.55% Avg for View: 57.55% (0.00%)	40.69% Avg for View: 40.69% (0.00%)	\$0.00 % of Total: 0.00% (\$0.00)
1. /	22,041 (15.96%)	17,642 (16.81%)	00:00:45	16,828 (29.95%)	34.80%	37.99%	\$0.00 (0.00%)
2. /recycling-center	5,487 (3.97%)	4,332 (4.13%)	00:02:02	3,528 (6.28%)	75.28%	68.16%	\$0.00 (0.00%)
3. /Curbside-Garbage-and-Recycling-Collection	5,435 (3.94%)	3,843 (3.66%)	00:02:11	2,302 (4.10%)	69.81%	58.91%	\$0.00 (0.00%)
4. /police-department	4,696 (3.40%)	3,619 (3.45%)	00:01:03	2,412 (4.29%)	51.00%	41.84%	\$0.00 (0.00%)
5. /contact-us	3,733 (2.70%)	3,315 (3.16%)	00:01:22	1,864 (3.32%)	80.74%	60.43%	\$0.00 (0.00%)
6. /village-board	3,514 (2.54%)	2,762 (2.63%)	00:00:59	833 (1.48%)	51.86%	25.01%	\$0.00 (0.00%)
7. /village-board-meetings-and-agendas	5,150 (3.73%)	2,717 (2.59%)	00:01:15	1,031 (1.84%)	48.88%	28.08%	\$0.00 (0.00%)
8. /election-information	4,015 (2.91%)	2,710 (2.58%)	00:02:37	1,957 (3.48%)	68.22%	59.08%	\$0.00 (0.00%)
9. /calendar-of-events	3,004 (2.18%)	2,373 (2.26%)	00:00:55	988 (1.76%)	74.09%	44.71%	\$0.00 (0.00%)
10. /employment	2,478 (1.79%)	1,952 (1.86%)	00:01:56	1,063 (1.89%)	78.83%	63.08%	\$0.00 (0.00%)
11. /police-services	2,224 (1.61%)	1,807 (1.72%)	00:01:30	1,014 (1.80%)	75.64%	51.26%	\$0.00 (0.00%)
12. /forms	1,997 (1.45%)	1,557 (1.48%)	00:02:03	485 (0.86%)	65.98%	44.92%	\$0.00 (0.00%)
13. /for-our-residents	1,920 (1.39%)	1,524 (1.45%)	00:00:50	860 (1.53%)	30.00%	25.94%	\$0.00 (0.00%)
14. /Department-of-Public-Works	1,938 (1.40%)	1,473 (1.40%)	00:00:33	279 (0.50%)	49.46%	20.74%	\$0.00 (0.00%)
15. /pay-a-bill	1,901 (1.38%)	1,463 (1.39%)	00:02:49	432 (0.77%)	71.30%	63.81%	\$0.00 (0.00%)
16. /staff-directory	1,519 (1.10%)	1,431 (1.36%)	00:02:44	1,009 (1.80%)	92.47%	82.95%	\$0.00 (0.00%)
17. /plan-commission-meetings-and-agendas	2,593 (1.88%)	1,301 (1.24%)	00:01:03	561 (1.00%)	58.29%	27.57%	\$0.00 (0.00%)
18. /departments	1,505 (1.09%)	1,208 (1.15%)	00:00:42	603 (1.07%)	19.73%	17.54%	\$0.00 (0.00%)
19. /plan-commission	1,660 (1.20%)	1,202 (1.15%)	00:00:33	283 (0.50%)	34.28%	16.75%	\$0.00 (0.00%)
20. /police-our-roster	1,487 (1.08%)	1,160 (1.11%)	00:01:57	430 (0.77%)	73.72%	55.08%	\$0.00 (0.00%)
21. /planning-and-development	1,698 (1.23%)	1,136 (1.08%)	00:01:54	586 (1.04%)	53.58%	42.82%	\$0.00 (0.00%)
22. /police-about	1,532 (1.11%)	1,121 (1.07%)	00:00:25	164 (0.29%)	40.24%	14.82%	\$0.00 (0.00%)
23. /whats-new	1,489 (1.08%)	1,110 (1.06%)	00:00:52	599 (1.07%)	57.93%	39.36%	\$0.00 (0.00%)
24. /home	1,593 (1.15%)	1,050 (1.00%)	00:01:03	161 (0.29%)	47.83%	23.41%	\$0.00 (0.00%)
25. /seasonal-dpw-services	1,319 (0.96%)	1,004 (0.96%)	00:01:01	581 (1.03%)	42.17%	34.87%	\$0.00 (0.00%)
26. /Treasurer	1,275 (0.92%)	1,000 (0.95%)	00:01:52	697 (1.24%)	76.61%	62.27%	\$0.00 (0.00%)
27. /Building-Inspection-Permits	1,214 (0.88%)	988 (0.94%)	00:02:06	595 (1.06%)	75.29%	66.97%	\$0.00 (0.00%)
28. /municipal-court	1,174 (0.85%)	959 (0.91%)	00:00:57	759 (1.35%)	49.67%	41.14%	\$0.00 (0.00%)

29.	/Utility-Information		1,226 <small>(0.89%)</small>	931 <small>(0.89%)</small>	00:01:36	554 <small>(0.99%)</small>	48.74%	39.72%	\$0.00 <small>(0.00%)</small>
30.	/projects		1,058 <small>(0.77%)</small>	898 <small>(0.86%)</small>	00:01:29	527 <small>(0.94%)</small>	87.10%	56.81%	\$0.00 <small>(0.00%)</small>
31.	/assessor-		1,109 <small>(0.80%)</small>	833 <small>(0.79%)</small>	00:02:40	604 <small>(1.08%)</small>	67.72%	61.77%	\$0.00 <small>(0.00%)</small>
32.	/police-contact-us		986 <small>(0.71%)</small>	819 <small>(0.78%)</small>	00:01:13	141 <small>(0.25%)</small>	82.27%	42.80%	\$0.00 <small>(0.00%)</small>
33.	/village-clerks-office		1,005 <small>(0.73%)</small>	690 <small>(0.66%)</small>	00:00:42	147 <small>(0.26%)</small>	54.42%	25.07%	\$0.00 <small>(0.00%)</small>
34.	/police-faq		812 <small>(0.59%)</small>	673 <small>(0.64%)</small>	00:02:04	440 <small>(0.78%)</small>	67.95%	60.59%	\$0.00 <small>(0.00%)</small>
35.	/Default.aspx		970 <small>(0.70%)</small>	654 <small>(0.62%)</small>	00:00:47	565 <small>(1.01%)</small>	11.86%	10.93%	\$0.00 <small>(0.00%)</small>
36.	/parks-and-recreation-department		751 <small>(0.54%)</small>	604 <small>(0.58%)</small>	00:01:28	395 <small>(0.70%)</small>	75.19%	62.85%	\$0.00 <small>(0.00%)</small>
37.	/municipal-court-pay-your-citation		858 <small>(0.62%)</small>	586 <small>(0.56%)</small>	00:02:01	329 <small>(0.59%)</small>	58.36%	56.06%	\$0.00 <small>(0.00%)</small>
38.	/cemetery-		642 <small>(0.46%)</small>	496 <small>(0.47%)</small>	00:04:24	335 <small>(0.60%)</small>	76.72%	68.69%	\$0.00 <small>(0.00%)</small>
39.	/recently-adopted-ordinances		694 <small>(0.50%)</small>	495 <small>(0.47%)</small>	00:01:26	211 <small>(0.38%)</small>	55.92%	43.37%	\$0.00 <small>(0.00%)</small>
40.	/police-resources		677 <small>(0.49%)</small>	485 <small>(0.46%)</small>	00:00:18	13 <small>(0.02%)</small>	69.23%	8.57%	\$0.00 <small>(0.00%)</small>
41.	/privacy-policy		471 <small>(0.34%)</small>	470 <small>(0.45%)</small>	00:00:56	465 <small>(0.83%)</small>	100.00%	99.36%	\$0.00 <small>(0.00%)</small>
42.	/our-community		554 <small>(0.40%)</small>	442 <small>(0.42%)</small>	00:00:33	102 <small>(0.18%)</small>	42.16%	25.27%	\$0.00 <small>(0.00%)</small>
43.	/transportation-utility		470 <small>(0.34%)</small>	438 <small>(0.42%)</small>	00:02:11	363 <small>(0.65%)</small>	87.33%	73.83%	\$0.00 <small>(0.00%)</small>
44.	/boards-committees		611 <small>(0.44%)</small>	430 <small>(0.41%)</small>	00:00:16	132 <small>(0.23%)</small>	77.27%	22.09%	\$0.00 <small>(0.00%)</small>
45.	/public-works-safety-committee		527 <small>(0.38%)</small>	427 <small>(0.41%)</small>	00:00:49	33 <small>(0.06%)</small>	72.73%	17.08%	\$0.00 <small>(0.00%)</small>
46.	/public-works-safety-committee-meetings-and-agendas		499 <small>(0.36%)</small>	389 <small>(0.37%)</small>	00:01:17	216 <small>(0.38%)</small>	89.35%	49.70%	\$0.00 <small>(0.00%)</small>
47.	/joint-review-board		397 <small>(0.29%)</small>	371 <small>(0.35%)</small>	00:00:10	279 <small>(0.50%)</small>	98.57%	70.28%	\$0.00 <small>(0.00%)</small>
48.	/police-commission-meetings-and-agendas		568 <small>(0.41%)</small>	354 <small>(0.34%)</small>	00:00:28	211 <small>(0.38%)</small>	86.26%	40.85%	\$0.00 <small>(0.00%)</small>
49.	/Police-Commission		383 <small>(0.28%)</small>	323 <small>(0.31%)</small>	00:00:36	49 <small>(0.09%)</small>	51.02%	18.28%	\$0.00 <small>(0.00%)</small>
50.	/report-a-concern		395 <small>(0.29%)</small>	312 <small>(0.30%)</small>	00:02:20	60 <small>(0.11%)</small>	70.00%	37.72%	\$0.00 <small>(0.00%)</small>
51.	/police-sex-offender-ordinance		372 <small>(0.27%)</small>	292 <small>(0.28%)</small>	00:02:38	259 <small>(0.46%)</small>	79.92%	72.85%	\$0.00 <small>(0.00%)</small>
52.	/fire-department		330 <small>(0.24%)</small>	290 <small>(0.28%)</small>	00:02:09	191 <small>(0.34%)</small>	78.01%	67.58%	\$0.00 <small>(0.00%)</small>
53.	/committee-opportunities		368 <small>(0.27%)</small>	286 <small>(0.27%)</small>	00:00:47	58 <small>(0.10%)</small>	84.48%	31.25%	\$0.00 <small>(0.00%)</small>
54.	/police-citation-payments		419 <small>(0.30%)</small>	285 <small>(0.27%)</small>	00:00:47	67 <small>(0.12%)</small>	58.21%	30.07%	\$0.00 <small>(0.00%)</small>
55.	/board-of-review-meetings-and-agendas		358 <small>(0.26%)</small>	274 <small>(0.26%)</small>	00:01:09	193 <small>(0.34%)</small>	93.26%	54.75%	\$0.00 <small>(0.00%)</small>
56.	/newsletter		290 <small>(0.21%)</small>	268 <small>(0.26%)</small>	00:01:01	190 <small>(0.34%)</small>	94.21%	71.38%	\$0.00 <small>(0.00%)</small>
57.	/joint-review-board-meetings-and-agendas		359 <small>(0.26%)</small>	267 <small>(0.25%)</small>	00:01:07	196 <small>(0.35%)</small>	92.35%	55.43%	\$0.00 <small>(0.00%)</small>
58.	/board-of-review		325 <small>(0.24%)</small>	263 <small>(0.25%)</small>	00:00:40	31 <small>(0.06%)</small>	58.06%	15.08%	\$0.00 <small>(0.00%)</small>
59.	/lake-level-order		373 <small>(0.27%)</small>	254 <small>(0.24%)</small>	00:01:52	152 <small>(0.27%)</small>	59.87%	45.58%	\$0.00 <small>(0.00%)</small>
60.	/zoning-board-of-appeals-meetings-and-agendas		307 <small>(0.22%)</small>	253 <small>(0.24%)</small>	00:00:53	191 <small>(0.34%)</small>	94.24%	65.47%	\$0.00 <small>(0.00%)</small>
61.	/police-annual-report		408 <small>(0.30%)</small>	245 <small>(0.23%)</small>	00:02:02	51 <small>(0.09%)</small>	52.94%	38.48%	\$0.00 <small>(0.00%)</small>
62.	/municipal-court-contact-us		259 <small>(0.19%)</small>	227 <small>(0.22%)</small>	00:03:49	110 <small>(0.20%)</small>	80.00%	68.34%	\$0.00 <small>(0.00%)</small>
63.	/pewaukee-lake-advisory-committe-meetings-and-agendas		229 <small>(0.17%)</small>	219 <small>(0.21%)</small>	00:00:59	170 <small>(0.30%)</small>	100.00%	76.42%	\$0.00 <small>(0.00%)</small>
64.	/burning-permits		240 <small>(0.17%)</small>	216 <small>(0.21%)</small>	00:01:57	144 <small>(0.26%)</small>	80.56%	60.83%	\$0.00 <small>(0.00%)</small>
65.	/Zoning-Board-of-Appeals		255 <small>(0.18%)</small>	213 <small>(0.20%)</small>	00:00:41	22 <small>(0.04%)</small>	50.00%	14.12%	\$0.00 <small>(0.00%)</small>
66.	/quiet-zones		222 <small>(0.16%)</small>	205 <small>(0.20%)</small>	00:01:03	77 <small>(0.14%)</small>	74.03%	41.44%	\$0.00 <small>(0.00%)</small>
67.	/presidents-letter		280 <small>(0.20%)</small>	204 <small>(0.19%)</small>	00:00:44	19 <small>(0.03%)</small>	73.68%	21.43%	\$0.00 <small>(0.00%)</small>
68.	/pewaukee-lakefront-fireworks-at-930-pm		223 <small>(0.16%)</small>	195 <small>(0.19%)</small>	00:00:51	19 <small>(0.03%)</small>	84.21%	53.81%	\$0.00 <small>(0.00%)</small>
69.	/oakton-avenue-railroad-crossing-ocr-ruling		207 <small>(0.15%)</small>	188 <small>(0.18%)</small>	00:01:02	24 <small>(0.04%)</small>	75.00%	25.60%	\$0.00 <small>(0.00%)</small>
70.	/village-board-meetings-and-agendas?Type=A&ID=252		233 <small>(0.17%)</small>	187 <small>(0.18%)</small>	00:01:40	20 <small>(0.04%)</small>	95.00%	33.91%	\$0.00 <small>(0.00%)</small>



71.	/2022-yard-waste-tags-now-available		210 (0.15%)	183 (0.17%)	00:00:57	41 (0.07%)	78.05%	39.52%	\$0.00 (0.00%)
72.	/community-relations		287 (0.21%)	180 (0.17%)	00:01:31	33 (0.06%)	63.64%	29.97%	\$0.00 (0.00%)
73.	/snow-plow-information		237 (0.17%)	178 (0.17%)	00:01:27	59 (0.11%)	77.97%	37.13%	\$0.00 (0.00%)
74.	/invasive-weeds		198 (0.14%)	174 (0.17%)	00:01:01	47 (0.08%)	82.98%	37.37%	\$0.00 (0.00%)
75.	/contact-us/		170 (0.12%)	168 (0.16%)	00:10:39	168 (0.30%)	98.21%	98.24%	\$0.00 (0.00%)
76.	/police-pewaukee-lake-patrol		208 (0.15%)	160 (0.15%)	00:01:05	107 (0.19%)	58.88%	46.15%	\$0.00 (0.00%)
77.	/municipal-court-frequently-asked-questions		197 (0.14%)	153 (0.15%)	00:01:05	34 (0.06%)	67.65%	31.98%	\$0.00 (0.00%)
78.	/bartenderoperator-licenses		214 (0.15%)	151 (0.14%)	00:01:45	117 (0.21%)	66.67%	57.48%	\$0.00 (0.00%)
79.	/strategic-plan		171 (0.12%)	149 (0.14%)	00:01:32	39 (0.07%)	84.62%	38.01%	\$0.00 (0.00%)
80.	/Events/MonthView.aspx?pageid=957&mid=1586&visdate1586=2022-11-01T00:00:00		202 (0.15%)	146 (0.14%)	00:00:46	20 (0.04%)	90.00%	36.63%	\$0.00 (0.00%)
81.	/Events/MonthView.aspx?pageid=957&mid=1586&visdate1586=2022-04-01T00:00:00		234 (0.17%)	139 (0.13%)	00:00:32	11 (0.02%)	81.82%	25.64%	\$0.00 (0.00%)
82.	/downtown-design-guidelines		156 (0.11%)	137 (0.13%)	00:00:53	18 (0.03%)	88.89%	21.15%	\$0.00 (0.00%)
83.	/municipal-court-upcoming-court-dates		205 (0.15%)	134 (0.13%)	00:00:40	12 (0.02%)	33.33%	15.61%	\$0.00 (0.00%)
84.	/pewaukee-public-library		154 (0.11%)	134 (0.13%)	00:00:47	67 (0.12%)	88.06%	59.09%	\$0.00 (0.00%)
85.	/pewaukee-lake-advisory-committee		158 (0.11%)	133 (0.13%)	00:00:45	23 (0.04%)	69.57%	19.62%	\$0.00 (0.00%)
86.	/sex-offender-residency-appeals-board		147 (0.11%)	130 (0.12%)	00:00:31	39 (0.07%)	87.18%	33.33%	\$0.00 (0.00%)
87.	/secure/login.aspx		174 (0.13%)	126 (0.12%)	00:00:37	79 (0.14%)	8.86%	6.90%	\$0.00 (0.00%)
88.	/committee-vacancies		145 (0.11%)	124 (0.12%)	00:00:15	4 (0.01%)	50.00%	6.90%	\$0.00 (0.00%)
89.	/adopted-resolutions		205 (0.15%)	123 (0.12%)	00:00:52	24 (0.04%)	58.33%	20.98%	\$0.00 (0.00%)
90.	/joint-park-recreation-board		141 (0.10%)	122 (0.12%)	00:01:08	23 (0.04%)	82.61%	26.95%	\$0.00 (0.00%)
91.	/the-historic-preservation-commission		130 (0.09%)	116 (0.11%)	00:00:29	21 (0.04%)	90.48%	23.85%	\$0.00 (0.00%)
92.	/municipal-court-court-procedures		172 (0.12%)	113 (0.11%)	00:01:24	12 (0.02%)	50.00%	20.35%	\$0.00 (0.00%)
93.	/wp-content/uploads/2012/01/Village-of-Pewaukee-Sign-Code-091.pdf		126 (0.09%)	107 (0.10%)	00:00:26	106 (0.19%)	2.83%	3.17%	\$0.00 (0.00%)
94.	/Events/MonthView.aspx?pageid=957&mid=1586&visdate1586=2022-10-01T00:00:00		153 (0.11%)	106 (0.10%)	00:00:56	8 (0.01%)	87.50%	26.80%	\$0.00 (0.00%)
95.	/police-ride-along-program		124 (0.09%)	106 (0.10%)	00:01:25	53 (0.09%)	73.58%	53.23%	\$0.00 (0.00%)
96.	/Events/MonthView.aspx?pageid=957&mid=1586&visdate1586=2022-07-01T00:00:00		142 (0.10%)	102 (0.10%)	00:00:22	3 (0.01%)	33.33%	16.90%	\$0.00 (0.00%)
97.	/Events/MonthView.aspx?pageid=957&mid=1586&visdate1586=2022-06-01T00:00:00		139 (0.10%)	101 (0.10%)	00:00:40	5 (0.01%)	40.00%	13.67%	\$0.00 (0.00%)
98.	/new-page-9		111 (0.08%)	98 (0.09%)	00:00:56	24 (0.04%)	79.17%	36.94%	\$0.00 (0.00%)
99.	/SiteMap.aspx		122 (0.09%)	97 (0.09%)	00:00:38	2 (0.00%)	100.00%	13.11%	\$0.00 (0.00%)
100.	/village-board-meetings-and-agendas?Type=A&ID=244		122 (0.09%)	97 (0.09%)	00:01:06	20 (0.04%)	55.00%	24.59%	\$0.00 (0.00%)
101.	/Data/Sites/38/media/planning-and-development/zoning2020-rev-date-6.4.2020.pdf		139 (0.10%)	96 (0.09%)	00:00:41	1 (0.00%)	0.00%	5.76%	\$0.00 (0.00%)
102.	/current-candidacy-information		112 (0.08%)	94 (0.09%)	00:01:11	14 (0.02%)	71.43%	31.25%	\$0.00 (0.00%)
103.	/labor-day-2022-09-05		108 (0.08%)	92 (0.09%)	00:01:15	88 (0.16%)	62.50%	61.11%	\$0.00 (0.00%)
104.	/Events/MonthView.aspx?pageid=957&mid=1586&visdate1586=2022-05-01T00:00:00		139 (0.10%)	91 (0.09%)	00:00:27	4 (0.01%)	75.00%	12.95%	\$0.00 (0.00%)
105.	/upcoming-events		104 (0.08%)	91 (0.09%)	00:00:16	2 (0.00%)	100.00%	13.46%	\$0.00 (0.00%)
106.	/village-board-meetings-and-agendas?Type=A&ID=247		116 (0.08%)	91 (0.09%)	00:01:34	17 (0.03%)	88.24%	31.90%	\$0.00 (0.00%)
107.	/village-board-meetings-and-agendas?Type=A&ID=249		121 (0.09%)	89 (0.08%)	00:01:45	14 (0.02%)	78.57%	23.97%	\$0.00 (0.00%)
108.	/trick-or-treat-4-7-pm-2021-10-30		93 (0.07%)	88 (0.08%)	00:01:27	84 (0.15%)	58.33%	59.14%	\$0.00 (0.00%)
109.	/village-board-meetings-and-agendas?Type=D&ID=252		111 (0.08%)	87 (0.08%)	00:02:55	9 (0.02%)	66.67%	43.24%	\$0.00 (0.00%)
110.	/agendas-meetings/village-board/		86 (0.06%)	86 (0.08%)	00:00:16	86 (0.15%)	98.84%	98.84%	\$0.00 (0.00%)
111.	/joint-library-board		98 (0.07%)	86 (0.08%)	00:00:25	17 (0.03%)	94.12%	25.51%	\$0.00 (0.00%)
112.	/municipal-court-helpful-information		125 (0.09%)	86 (0.08%)	00:02:12	8 (0.01%)	100.00%	20.80%	\$0.00 (0.00%)
113.	/agendas-meetings/plan-commission/		85	85	00:00:00	85	100.00%	100.00%	\$0.00

	/agenda-meetings/plan-commission/		84 (0.06%)	84 (0.08%)	00:02:34	84 (0.15%)	98.81%	98.81%	\$0.00 (0.00%)
114.	/assessmentproperty-data/		84 (0.06%)	84 (0.08%)	00:02:34	84 (0.15%)	98.81%	98.81%	\$0.00 (0.00%)
115.	/is-your-waukesha-county-property-at-risk-of-flooding/		83 (0.06%)	83 (0.08%)	00:00:00	83 (0.15%)	100.00%	100.00%	\$0.00 (0.00%)
116.	/village-board-meetings-and-agendas?Type=A&ID=256		103 (0.07%)	83 (0.08%)	00:00:52	18 (0.03%)	77.78%	41.75%	\$0.00 (0.00%)
117.	/property-taxes/		82 (0.06%)	82 (0.08%)	00:00:00	82 (0.15%)	100.00%	100.00%	\$0.00 (0.00%)
118.	/village-board-meetings-and-agendas?Type=A&ID=258		97 (0.07%)	82 (0.08%)	00:00:46	12 (0.02%)	100.00%	28.87%	\$0.00 (0.00%)
119.	/2019-property-tax-bills/		81 (0.06%)	81 (0.08%)	00:00:00	81 (0.14%)	100.00%	100.00%	\$0.00 (0.00%)
120.	/plan-commission-meetings-and-agendas?Type=A&ID=242		98 (0.07%)	78 (0.07%)	00:00:37	13 (0.02%)	76.92%	25.51%	\$0.00 (0.00%)
121.	/plan-commission-meetings-and-agendas?Type=A&ID=229		99 (0.07%)	77 (0.07%)	00:00:32	1 (0.00%)	0.00%	14.14%	\$0.00 (0.00%)
122.	/village-board-meetings-and-agendas?Type=A&ID=230		106 (0.08%)	75 (0.07%)	00:00:31	11 (0.02%)	36.36%	17.92%	\$0.00 (0.00%)
123.	/recycling-center-opens-saturday		81 (0.06%)	74 (0.07%)	00:00:15	15 (0.03%)	93.33%	48.15%	\$0.00 (0.00%)
124.	/village-board-meetings-and-agendas?Type=A&ID=248		90 (0.07%)	73 (0.07%)	00:00:47	9 (0.02%)	88.89%	24.44%	\$0.00 (0.00%)
125.	/contact-2/		72 (0.05%)	72 (0.07%)	00:00:00	72 (0.13%)	100.00%	100.00%	\$0.00 (0.00%)
126.	/Events/MonthView.aspx?pageid=957&mid=1586&visdate1586=2022-09-01T00:00:00		107 (0.08%)	72 (0.07%)	00:00:09	1 (0.00%)	0.00%	13.08%	\$0.00 (0.00%)
127.	/2022-mill-and-pave-for-timber-ridge-		74 (0.05%)	70 (0.07%)	00:01:00	25 (0.04%)	92.00%	55.41%	\$0.00 (0.00%)
128.	/independence-day-2022-07-04		80 (0.06%)	70 (0.07%)	00:00:53	23 (0.04%)	69.57%	43.75%	\$0.00 (0.00%)
129.	/staffdirectory		69 (0.05%)	69 (0.07%)	00:00:00	69 (0.12%)	100.00%	100.00%	\$0.00 (0.00%)
130.	/volunteers-needed-for-water-sampling		72 (0.05%)	68 (0.06%)	00:01:10	2 (0.00%)	100.00%	31.94%	\$0.00 (0.00%)
131.	/Events/MonthView.aspx?pageid=957&mid=1586&visdate1586=2022-12-01T00:00:00		99 (0.07%)	66 (0.06%)	00:00:23	2 (0.00%)	100.00%	25.25%	\$0.00 (0.00%)
132.	/plan-commission-meetings-and-agendas?Type=A&ID=220		92 (0.07%)	66 (0.06%)	00:00:29	0 (0.00%)	0.00%	17.39%	\$0.00 (0.00%)
133.	/trick-or-treat-in-the-village-2022-10-29		74 (0.05%)	66 (0.06%)	00:00:37	28 (0.05%)	89.29%	71.62%	\$0.00 (0.00%)
134.	/budget		93 (0.07%)	65 (0.06%)	00:01:29	27 (0.05%)	77.78%	41.94%	\$0.00 (0.00%)
135.	/plan-commission-meetings-and-agendas?Type=A&ID=216		89 (0.06%)	65 (0.06%)	00:00:55	4 (0.01%)	25.00%	22.47%	\$0.00 (0.00%)
136.	/village-board/		67 (0.05%)	65 (0.06%)	00:00:18	61 (0.11%)	14.75%	14.93%	\$0.00 (0.00%)
137.	/memorial-day-village-hall-closed-library-closed-2021-05-31		70 (0.05%)	63 (0.06%)	00:00:40	62 (0.11%)	61.29%	65.71%	\$0.00 (0.00%)
138.	/plan-commission-meetings-and-agendas?Type=A&ID=236		71 (0.05%)	63 (0.06%)	00:00:58	6 (0.01%)	100.00%	15.49%	\$0.00 (0.00%)
139.	/plan-commission-meetings-and-agendas?Type=A&ID=246		71 (0.05%)	63 (0.06%)	00:00:57	13 (0.02%)	84.62%	32.39%	\$0.00 (0.00%)
140.	/static-water-pressure		77 (0.06%)	63 (0.06%)	00:00:49	5 (0.01%)	100.00%	23.38%	\$0.00 (0.00%)
141.	/village-board-meetings-and-agendas?Type=D&ID=264		100 (0.07%)	63 (0.06%)	00:00:46	10 (0.02%)	100.00%	42.00%	\$0.00 (0.00%)
142.	/village-board-meetings-and-agendas?Type=A&ID=240		87 (0.06%)	62 (0.06%)	00:01:13	9 (0.02%)	88.89%	21.84%	\$0.00 (0.00%)
143.	/plan-commission-meetings-and-agendas?Type=A&ID=257		85 (0.06%)	61 (0.06%)	00:01:25	10 (0.02%)	80.00%	28.24%	\$0.00 (0.00%)
144.	/police-lacs-citizens-police-academy		90 (0.07%)	61 (0.06%)	00:01:30	22 (0.04%)	86.36%	38.89%	\$0.00 (0.00%)
145.	/village-board-meetings-and-agendas?Type=A&ID=235		78 (0.06%)	60 (0.06%)	00:00:38	6 (0.01%)	100.00%	19.23%	\$0.00 (0.00%)
146.	/plan-commission-meetings-and-agendas?Type=A&ID=250		76 (0.06%)	58 (0.06%)	00:00:49	10 (0.02%)	100.00%	26.32%	\$0.00 (0.00%)
147.	/village-board-meetings-and-agendas?Type=A&ID=219		75 (0.05%)	58 (0.06%)	00:00:51	2 (0.00%)	100.00%	24.00%	\$0.00 (0.00%)
148.	/trucking-and-weight-restrictions		79 (0.06%)	57 (0.05%)	00:00:38	0 (0.00%)	0.00%	10.13%	\$0.00 (0.00%)
149.	/downtown-speed-humps-information		57 (0.04%)	56 (0.05%)	00:00:37	2 (0.00%)	50.00%	26.32%	\$0.00 (0.00%)
150.	/Events/MonthView.aspx?pageid=957&mid=1586&visdate1586=2022-08-01T00:00:00		93 (0.07%)	56 (0.05%)	00:00:21	0 (0.00%)	0.00%	10.75%	\$0.00 (0.00%)
151.	/police-internet-exchange-location		66 (0.05%)	56 (0.05%)	00:02:21	42 (0.07%)	78.57%	72.73%	\$0.00 (0.00%)
152.	/the-new-utility-portal-is-here		60 (0.04%)	56 (0.05%)	00:00:47	6 (0.01%)	100.00%	50.00%	\$0.00 (0.00%)
153.	/village-board-meetings-and-agendas?Type=A&ID=238		71 (0.05%)	56 (0.05%)	00:01:38	10 (0.02%)	90.00%	30.99%	\$0.00 (0.00%)
154.	/spam-calls-		56 (0.04%)	55 (0.05%)	00:00:23	31 (0.06%)	93.55%	73.21%	\$0.00 (0.00%)
155.	/admin-whatsnew		97 (0.07%)	54 (0.05%)	00:01:11	0 (0.00%)	0.00%	3.09%	\$0.00 (0.00%)



















156.	/village-board-meetings-and-agendas?Type=A&ID=217		80 <small>(0.06%)</small>	54 <small>(0.05%)</small>	00:01:06	5 <small>(0.01%)</small>	60.00%	20.00%	\$0.00 <small>(0.00%)</small>
157.	/transportation-utility?embedded_webview=true		54 <small>(0.04%)</small>	53 <small>(0.05%)</small>	00:01:57	53 <small>(0.09%)</small>	98.11%	98.15%	\$0.00 <small>(0.00%)</small>
158.	/village-board-meetings-and-agendas?Type=D&ID=261		79 <small>(0.06%)</small>	53 <small>(0.05%)</small>	00:01:28	10 <small>(0.02%)</small>	80.00%	35.44%	\$0.00 <small>(0.00%)</small>
159.	/trucking-and-weight-restrictions-1		57 <small>(0.04%)</small>	51 <small>(0.05%)</small>	00:00:42	4 <small>(0.01%)</small>	100.00%	40.35%	\$0.00 <small>(0.00%)</small>
160.	/consumer-confidence-report-		83 <small>(0.06%)</small>	50 <small>(0.05%)</small>	00:02:13	3 <small>(0.01%)</small>	100.00%	34.94%	\$0.00 <small>(0.00%)</small>
161.	/Events/MonthView.aspx?pageid=957&mid=1586&visdate1586=2023-01-01T00:00:00		126 <small>(0.09%)</small>	50 <small>(0.05%)</small>	00:00:46	3 <small>(0.01%)</small>	100.00%	15.08%	\$0.00 <small>(0.00%)</small>
162.	/lake-patrol/		56 <small>(0.04%)</small>	50 <small>(0.05%)</small>	00:02:40	48 <small>(0.09%)</small>	79.17%	78.57%	\$0.00 <small>(0.00%)</small>
163.	/driveway-plowing-recommendations-1		51 <small>(0.04%)</small>	49 <small>(0.05%)</small>	00:01:21	0 <small>(0.00%)</small>	0.00%	19.61%	\$0.00 <small>(0.00%)</small>
164.	/comprehensive-land-use-plan-		62 <small>(0.04%)</small>	48 <small>(0.05%)</small>	00:01:20	4 <small>(0.01%)</small>	100.00%	37.10%	\$0.00 <small>(0.00%)</small>
165.	/Events/MonthView.aspx?pageid=957&mid=1586&visdate1586=2022-03-01T00:00:00		92 <small>(0.07%)</small>	48 <small>(0.05%)</small>	00:00:06	0 <small>(0.00%)</small>	0.00%	7.61%	\$0.00 <small>(0.00%)</small>
166.	/village-board-meetings-and-agendas?Type=A&ID=243		54 <small>(0.04%)</small>	48 <small>(0.05%)</small>	00:00:45	6 <small>(0.01%)</small>	100.00%	25.93%	\$0.00 <small>(0.00%)</small>
167.	/community-shredding-event-on-october-22-2022		55 <small>(0.04%)</small>	47 <small>(0.04%)</small>	00:00:27	0 <small>(0.00%)</small>	0.00%	23.64%	\$0.00 <small>(0.00%)</small>
168.	/no-yard-waste-or-brush-will-be-collected-during-leaf-pickup-2022-11-14		52 <small>(0.04%)</small>	47 <small>(0.04%)</small>	00:02:30	31 <small>(0.06%)</small>	32.26%	40.38%	\$0.00 <small>(0.00%)</small>
169.	/police-internet-crimes-against-children		64 <small>(0.05%)</small>	47 <small>(0.04%)</small>	00:00:53	22 <small>(0.04%)</small>	59.09%	42.19%	\$0.00 <small>(0.00%)</small>
170.	/search-results?usterm=Garbage		58 <small>(0.04%)</small>	47 <small>(0.04%)</small>	00:00:18	3 <small>(0.01%)</small>	66.67%	13.79%	\$0.00 <small>(0.00%)</small>
171.	/in-person-absentee-voting-800-am-to-430-pm-2022-08-03		47 <small>(0.03%)</small>	45 <small>(0.04%)</small>	00:01:12	31 <small>(0.06%)</small>	38.71%	36.17%	\$0.00 <small>(0.00%)</small>
172.	/pewaukee-lakefront-fireworks		53 <small>(0.04%)</small>	45 <small>(0.04%)</small>	00:00:39	5 <small>(0.01%)</small>	100.00%	39.62%	\$0.00 <small>(0.00%)</small>
173.	/special-assessment-letters		57 <small>(0.04%)</small>	45 <small>(0.04%)</small>	00:00:54	21 <small>(0.04%)</small>	85.71%	47.37%	\$0.00 <small>(0.00%)</small>
174.	/village-board-meetings-and-agendas?Type=A&ID=225		66 <small>(0.05%)</small>	45 <small>(0.04%)</small>	00:00:16	2 <small>(0.00%)</small>	0.00%	15.15%	\$0.00 <small>(0.00%)</small>
175.	/village-board-meetings-and-agendas?Type=M&ID=247		53 <small>(0.04%)</small>	45 <small>(0.04%)</small>	00:03:20	6 <small>(0.01%)</small>	100.00%	33.96%	\$0.00 <small>(0.00%)</small>
176.	/know-before-you-throw--1		47 <small>(0.03%)</small>	44 <small>(0.04%)</small>	00:00:30	2 <small>(0.00%)</small>	50.00%	31.91%	\$0.00 <small>(0.00%)</small>
177.	/village-board-meetings-and-agendas?Type=M&ID=248		54 <small>(0.04%)</small>	44 <small>(0.04%)</small>	00:02:47	7 <small>(0.01%)</small>	100.00%	33.33%	\$0.00 <small>(0.00%)</small>
178.	/volunteers-needed-for-water-sampling-		52 <small>(0.04%)</small>	43 <small>(0.04%)</small>	00:02:31	11 <small>(0.02%)</small>	81.82%	38.46%	\$0.00 <small>(0.00%)</small>
179.	/plan-commission-meetings-and-agendas?Type=D&ID=262		68 <small>(0.05%)</small>	42 <small>(0.04%)</small>	00:01:19	12 <small>(0.02%)</small>	83.33%	26.47%	\$0.00 <small>(0.00%)</small>
180.	/in-person-absentee-voting-800-am-to-430-pm-2022-10-25		44 <small>(0.03%)</small>	40 <small>(0.04%)</small>	00:00:57	14 <small>(0.02%)</small>	71.43%	61.36%	\$0.00 <small>(0.00%)</small>
181.	/village-board-meetings-and-agendas?Type=M&ID=244		47 <small>(0.03%)</small>	40 <small>(0.04%)</small>	00:02:13	7 <small>(0.01%)</small>	85.71%	36.17%	\$0.00 <small>(0.00%)</small>
182.	/FormWizard/FileUpload.aspx?mid=1599&pageid=964&finished=true		64 <small>(0.05%)</small>	39 <small>(0.04%)</small>	00:01:26	5 <small>(0.01%)</small>	80.00%	51.56%	\$0.00 <small>(0.00%)</small>
183.	/sex-offender-residency-appeals-board-meetings-and-agendas		39 <small>(0.03%)</small>	39 <small>(0.04%)</small>	00:00:05	8 <small>(0.01%)</small>	100.00%	23.08%	\$0.00 <small>(0.00%)</small>
184.	/sitemap.aspx		53 <small>(0.04%)</small>	39 <small>(0.04%)</small>	00:00:24	2 <small>(0.00%)</small>	50.00%	9.43%	\$0.00 <small>(0.00%)</small>
185.	/village-board-meetings-and-agendas?Type=A&ID=223		53 <small>(0.04%)</small>	39 <small>(0.04%)</small>	00:00:34	2 <small>(0.00%)</small>	50.00%	13.21%	\$0.00 <small>(0.00%)</small>
186.	/gross-alpha-notice		43 <small>(0.03%)</small>	38 <small>(0.04%)</small>	00:01:08	5 <small>(0.01%)</small>	60.00%	30.23%	\$0.00 <small>(0.00%)</small>
187.	/gross-alpha-notice-712022		47 <small>(0.03%)</small>	38 <small>(0.04%)</small>	00:00:38	5 <small>(0.01%)</small>	80.00%	23.40%	\$0.00 <small>(0.00%)</small>
188.	/search-results?usterm=		56 <small>(0.04%)</small>	38 <small>(0.04%)</small>	00:00:41	1 <small>(0.00%)</small>	0.00%	12.50%	\$0.00 <small>(0.00%)</small>
189.	/village-board-meetings-and-agendas?Type=D&ID=268		55 <small>(0.04%)</small>	38 <small>(0.04%)</small>	00:01:36	12 <small>(0.02%)</small>	83.33%	38.18%	\$0.00 <small>(0.00%)</small>
190.	/village-board-meetings-and-agendas?Type=M&ID=235		43 <small>(0.03%)</small>	38 <small>(0.04%)</small>	00:03:19	7 <small>(0.01%)</small>	100.00%	32.56%	\$0.00 <small>(0.00%)</small>
191.	/village-board-meetings-and-agendas?Type=M&ID=252		39 <small>(0.03%)</small>	37 <small>(0.04%)</small>	00:02:45	10 <small>(0.02%)</small>	80.00%	33.33%	\$0.00 <small>(0.00%)</small>
192.	/downtown-lakefront-		45 <small>(0.03%)</small>	36 <small>(0.03%)</small>	00:00:36	2 <small>(0.00%)</small>	100.00%	17.78%	\$0.00 <small>(0.00%)</small>
193.	/gross-alpha-notice-1		43 <small>(0.03%)</small>	36 <small>(0.03%)</small>	00:02:22	3 <small>(0.01%)</small>	66.67%	39.53%	\$0.00 <small>(0.00%)</small>
194.	/search-results?usterm=gabage		41 <small>(0.03%)</small>	36 <small>(0.03%)</small>	00:00:14	1 <small>(0.00%)</small>	0.00%	2.44%	\$0.00 <small>(0.00%)</small>
195.	/search-results?usterm=zoning map		53 <small>(0.04%)</small>	36 <small>(0.03%)</small>	00:01:11	0 <small>(0.00%)</small>	0.00%	22.64%	\$0.00 <small>(0.00%)</small>
196.	/the-historic-preservation-commission-meetings-and-agendas		39 <small>(0.03%)</small>	36 <small>(0.03%)</small>	00:00:12	1 <small>(0.00%)</small>	100.00%	5.13%	\$0.00 <small>(0.00%)</small>
197.	/village-board-meetings-and-agendas?Type=M&ID=240		45 <small>(0.03%)</small>	35 <small>(0.03%)</small>	00:02:07	6 <small>(0.01%)</small>	100.00%	26.67%	\$0.00 <small>(0.00%)</small>









































198.	/village-board-meetings-and-agendas?Type=M&ID=238		38 <small>(0.03%)</small>	34 <small>(0.03%)</small>	00:01:40	9 <small>(0.02%)</small>	88.89%	36.84%	\$0.00 <small>(0.00%)</small>
199.	/?fbclid=IwAR17xbhdulzkCIJRp3ohQK73jaxafOfFk0ucnLGIQ-ZMM4GuSDzYhn5PGUA		41 <small>(0.03%)</small>	33 <small>(0.03%)</small>	00:01:22	33 <small>(0.06%)</small>	9.09%	9.76%	\$0.00 <small>(0.00%)</small>
200.	/aquatic-plant-collection-policy		39 <small>(0.03%)</small>	33 <small>(0.03%)</small>	00:00:20	0 <small>(0.00%)</small>	0.00%	5.13%	\$0.00 <small>(0.00%)</small>
201.	/village-board-meetings-and-agendas?Type=M&ID=256		41 <small>(0.03%)</small>	33 <small>(0.03%)</small>	00:01:45	9 <small>(0.02%)</small>	77.78%	31.71%	\$0.00 <small>(0.00%)</small>
202.	/admin-banner-alert		101 <small>(0.07%)</small>	32 <small>(0.03%)</small>	00:00:08	1 <small>(0.00%)</small>	0.00%	2.97%	\$0.00 <small>(0.00%)</small>
203.	/board-of-review-meetings-and-agendas?Type=A&ID=233		43 <small>(0.03%)</small>	32 <small>(0.03%)</small>	00:00:38	6 <small>(0.01%)</small>	83.33%	20.93%	\$0.00 <small>(0.00%)</small>
204.	/joint-review-board-meetings-and-agendas?Type=A&ID=251		39 <small>(0.03%)</small>	32 <small>(0.03%)</small>	00:00:36	20 <small>(0.04%)</small>	65.00%	35.90%	\$0.00 <small>(0.00%)</small>
205.	/plan-commission-meetings-and-agendas?Type=D&ID=267		52 <small>(0.04%)</small>	32 <small>(0.03%)</small>	00:01:46	9 <small>(0.02%)</small>	100.00%	36.54%	\$0.00 <small>(0.00%)</small>
206.	/plan-commission-meetings-and-agendas?Type=M&ID=242		38 <small>(0.03%)</small>	32 <small>(0.03%)</small>	00:03:27	2 <small>(0.00%)</small>	100.00%	34.21%	\$0.00 <small>(0.00%)</small>
207.	/police-shop-with-cops		37 <small>(0.03%)</small>	32 <small>(0.03%)</small>	00:00:23	4 <small>(0.01%)</small>	100.00%	32.43%	\$0.00 <small>(0.00%)</small>
208.	/public-works-safety-committee-meetings-and-agendas?Type=A&ID=245		42 <small>(0.03%)</small>	32 <small>(0.03%)</small>	00:02:00	13 <small>(0.02%)</small>	84.62%	40.48%	\$0.00 <small>(0.00%)</small>
209.	/village-board-meetings-and-agendas?Type=A&ID=214		38 <small>(0.03%)</small>	32 <small>(0.03%)</small>	00:00:48	4 <small>(0.01%)</small>	100.00%	23.68%	\$0.00 <small>(0.00%)</small>
210.	/village-board-meetings-and-agendas?Type=D&ID=269		53 <small>(0.04%)</small>	32 <small>(0.03%)</small>	00:02:01	8 <small>(0.01%)</small>	100.00%	33.96%	\$0.00 <small>(0.00%)</small>
211.	/village-board-meetings-and-agendas?Type=M&ID=219		34 <small>(0.02%)</small>	32 <small>(0.03%)</small>	00:01:57	8 <small>(0.01%)</small>	100.00%	35.29%	\$0.00 <small>(0.00%)</small>
212.	/police-vacation-home-checks		37 <small>(0.03%)</small>	31 <small>(0.03%)</small>	00:01:09	5 <small>(0.01%)</small>	100.00%	32.43%	\$0.00 <small>(0.00%)</small>
213.	/village-board-meetings-and-agendas?New=Y		33 <small>(0.02%)</small>	31 <small>(0.03%)</small>	00:02:08	0 <small>(0.00%)</small>	0.00%	3.03%	\$0.00 <small>(0.00%)</small>
214.	/village-board-meetings-and-agendas?Type=D&ID=275		44 <small>(0.03%)</small>	31 <small>(0.03%)</small>	00:02:14	10 <small>(0.02%)</small>	90.00%	34.09%	\$0.00 <small>(0.00%)</small>
215.	/village-board-meetings-and-agendas?Type=D&ID=277		47 <small>(0.03%)</small>	31 <small>(0.03%)</small>	00:02:28	12 <small>(0.02%)</small>	66.67%	40.43%	\$0.00 <small>(0.00%)</small>
216.	/2022-spring-election--2022-04-05		36 <small>(0.03%)</small>	30 <small>(0.03%)</small>	00:02:40	3 <small>(0.01%)</small>	100.00%	55.56%	\$0.00 <small>(0.00%)</small>
217.	/recycling-household-waste/		36 <small>(0.03%)</small>	30 <small>(0.03%)</small>	00:00:40	28 <small>(0.05%)</small>	42.86%	38.89%	\$0.00 <small>(0.00%)</small>
218.	/village-board-meetings-and-agendas?Type=M&ID=258		33 <small>(0.02%)</small>	30 <small>(0.03%)</small>	00:02:13	6 <small>(0.01%)</small>	83.33%	36.36%	\$0.00 <small>(0.00%)</small>
219.	/search-results?ustems=Trick or treat		38 <small>(0.03%)</small>	29 <small>(0.03%)</small>	00:01:02	2 <small>(0.00%)</small>	100.00%	23.68%	\$0.00 <small>(0.00%)</small>
220.	/village-board-meetings-and-agendas?Type=A&ID=227		50 <small>(0.04%)</small>	29 <small>(0.03%)</small>	00:00:12	0 <small>(0.00%)</small>	0.00%	10.00%	\$0.00 <small>(0.00%)</small>
221.	/village-board-meetings-and-agendas?Type=D&ID=249		48 <small>(0.03%)</small>	29 <small>(0.03%)</small>	00:01:52	2 <small>(0.00%)</small>	0.00%	25.00%	\$0.00 <small>(0.00%)</small>
222.	/village-board-meetings-and-agendas?Type=M&ID=223		33 <small>(0.02%)</small>	29 <small>(0.03%)</small>	00:01:16	2 <small>(0.00%)</small>	50.00%	21.21%	\$0.00 <small>(0.00%)</small>
223.	/police-dare		29 <small>(0.02%)</small>	28 <small>(0.03%)</small>	00:00:30	10 <small>(0.02%)</small>	100.00%	44.83%	\$0.00 <small>(0.00%)</small>
224.	/village-board-meetings-and-agendas?Type=M&ID=249		30 <small>(0.02%)</small>	28 <small>(0.03%)</small>	00:01:07	8 <small>(0.01%)</small>	100.00%	43.33%	\$0.00 <small>(0.00%)</small>
225.	/7-pm-village-board-meeting--2022-07-19		37 <small>(0.03%)</small>	27 <small>(0.03%)</small>	00:00:14	3 <small>(0.01%)</small>	33.33%	13.51%	\$0.00 <small>(0.00%)</small>
226.	/help-for-wisconsin-families		29 <small>(0.02%)</small>	27 <small>(0.03%)</small>	00:02:08	3 <small>(0.01%)</small>	66.67%	31.03%	\$0.00 <small>(0.00%)</small>
227.	/national-night-out-by-village-pd-2022-08-02		28 <small>(0.02%)</small>	27 <small>(0.03%)</small>	00:01:51	2 <small>(0.00%)</small>	100.00%	57.14%	\$0.00 <small>(0.00%)</small>
228.	/plan-commission-meetings-and-agendas?Type=D&ID=270		35 <small>(0.03%)</small>	27 <small>(0.03%)</small>	00:00:41	9 <small>(0.02%)</small>	100.00%	62.86%	\$0.00 <small>(0.00%)</small>
229.	/village-board-meetings-and-agendas?Type=D&ID=266		48 <small>(0.03%)</small>	27 <small>(0.03%)</small>	00:01:41	7 <small>(0.01%)</small>	85.71%	27.08%	\$0.00 <small>(0.00%)</small>
230.	/Blog/ViewArchive.aspx?month=3&year=2022&pageid=1098&mid=2045		35 <small>(0.03%)</small>	26 <small>(0.02%)</small>	00:00:19	1 <small>(0.00%)</small>	100.00%	17.14%	\$0.00 <small>(0.00%)</small>
231.	/Events/MonthView.aspx?pageid=957&mid=1586&visdate1586=2022-02-01T00:00:00		62 <small>(0.04%)</small>	26 <small>(0.02%)</small>	00:00:15	0 <small>(0.00%)</small>	0.00%	4.84%	\$0.00 <small>(0.00%)</small>
232.	/police-commission-meetings-and-agendas?Type=A&ID=234		29 <small>(0.02%)</small>	26 <small>(0.02%)</small>	00:00:34	5 <small>(0.01%)</small>	100.00%	31.03%	\$0.00 <small>(0.00%)</small>
233.	/public-works-safety-committee-meetings-and-agendas?Type=A&ID=253		30 <small>(0.02%)</small>	26 <small>(0.02%)</small>	00:00:48	8 <small>(0.01%)</small>	100.00%	40.00%	\$0.00 <small>(0.00%)</small>
234.	/search-results?ustems=zoning		32 <small>(0.02%)</small>	26 <small>(0.02%)</small>	00:00:40	0 <small>(0.00%)</small>	0.00%	12.50%	\$0.00 <small>(0.00%)</small>
235.	/tel		41 <small>(0.03%)</small>	26 <small>(0.02%)</small>	00:00:12	4 <small>(0.01%)</small>	75.00%	34.15%	\$0.00 <small>(0.00%)</small>
236.	/village-board-meetings-and-agendas?Type=D&ID=271		33 <small>(0.02%)</small>	26 <small>(0.02%)</small>	00:01:40	12 <small>(0.02%)</small>	83.33%	54.55%	\$0.00 <small>(0.00%)</small>
237.	/2022-crack-sealing-		28 <small>(0.02%)</small>	25 <small>(0.02%)</small>	00:00:36	0 <small>(0.00%)</small>	0.00%	7.14%	\$0.00 <small>(0.00%)</small>
238.	/christmas-day-2022-12-25		25 <small>(0.02%)</small>	25 <small>(0.02%)</small>	00:00:33	23 <small>(0.04%)</small>	73.91%	68.00%	\$0.00 <small>(0.00%)</small>
239.	/default.aspx		25 <small>(0.02%)</small>	25 <small>(0.02%)</small>	00:00:27	7 <small>(0.01%)</small>	42.86%	20.00%	\$0.00 <small>(0.00%)</small>
240.	/new-years-eve-2022-12-31		27 <small>(0.02%)</small>	25 <small>(0.02%)</small>	00:04:24	25 <small>(0.04%)</small>	92.00%	98.90%	\$0.00 <small>(0.00%)</small>

























240.	/new-years-eve-2022-12-31		29 (0.02%)	25 (0.02%)	00:04:34	11 (0.04%)	92.00%	88.89%	\$0.00 (0.00%)
241.	/police-commission-meetings-and-agendas?Type=A&ID=255		29 (0.02%)	25 (0.02%)	00:00:36	11 (0.02%)	100.00%	44.83%	\$0.00 (0.00%)
242.	/search-results?ustems=Parking		34 (0.02%)	25 (0.02%)	00:00:15	2 (0.00%)	50.00%	5.88%	\$0.00 (0.00%)
243.	/village-board-meetings-and-agendas?Type=D&ID=230		42 (0.03%)	25 (0.02%)	00:02:19	1 (0.00%)	100.00%	38.10%	\$0.00 (0.00%)
244.	/Admin/AdminMenu.aspx		47 (0.03%)	24 (0.02%)	00:00:15	2 (0.00%)	0.00%	2.13%	\$0.00 (0.00%)
245.	/Admin/ModuleSettings.aspx?mid=1590&pageid=961		27 (0.02%)	24 (0.02%)	00:00:12	0 (0.00%)	0.00%	0.00%	\$0.00 (0.00%)
246.	/new-payment-and-invoice-portal-coming-soon		25 (0.02%)	24 (0.02%)	00:00:26	0 (0.00%)	0.00%	28.00%	\$0.00 (0.00%)
247.	/plan-commission-meetings-and-agendas?Type=M&ID=250		33 (0.02%)	24 (0.02%)	00:01:18	3 (0.01%)	100.00%	15.15%	\$0.00 (0.00%)
248.	/village-board-meetings-and-agendas?Type=D&ID=244		29 (0.02%)	24 (0.02%)	00:03:23	4 (0.01%)	50.00%	37.93%	\$0.00 (0.00%)
249.	/village-board-meetings-and-agendas?Type=M&ID=243		29 (0.02%)	24 (0.02%)	00:03:08	6 (0.01%)	100.00%	34.48%	\$0.00 (0.00%)
250.	/Blog/EditPost.aspx?mid=2045&pageid=1098		27 (0.02%)	23 (0.02%)	00:04:53	0 (0.00%)	0.00%	7.41%	\$0.00 (0.00%)
251.	/Events/ListView.aspx?pageid=957&mid=1586		28 (0.02%)	23 (0.02%)	00:00:36	0 (0.00%)	0.00%	25.00%	\$0.00 (0.00%)
252.	/HtmlEdit.aspx?mid=1590&pageid=961		37 (0.03%)	23 (0.02%)	00:01:23	0 (0.00%)	0.00%	2.70%	\$0.00 (0.00%)
253.	/memorial-day--2022-05-30		27 (0.02%)	23 (0.02%)	00:00:28	1 (0.00%)	100.00%	33.33%	\$0.00 (0.00%)
254.	/plan-commission-meetings-and-agendas?Type=D&ID=242		36 (0.03%)	23 (0.02%)	00:03:03	2 (0.00%)	100.00%	30.56%	\$0.00 (0.00%)
255.	/village-board-meetings-and-agendas?Type=M&ID=230		24 (0.02%)	23 (0.02%)	00:01:23	6 (0.01%)	66.67%	37.50%	\$0.00 (0.00%)
256.	/2nd-round-leaf-collection-leaves-out-by-7-am-november-7th-2022-11-07		24 (0.02%)	22 (0.02%)	00:00:23	8 (0.01%)	50.00%	37.50%	\$0.00 (0.00%)
257.	/audit		30 (0.02%)	22 (0.02%)	00:01:26	2 (0.00%)	0.00%	26.67%	\$0.00 (0.00%)
258.	/plan-commission-meetings-and-agendas?Type=D&ID=274		33 (0.02%)	22 (0.02%)	00:01:33	9 (0.02%)	100.00%	51.52%	\$0.00 (0.00%)
259.	/police-commission-meetings-and-agendas?Type=A&ID=241		22 (0.02%)	22 (0.02%)	00:00:18	8 (0.01%)	87.50%	36.36%	\$0.00 (0.00%)
260.	/village-board-meetings-and-agendas?Type=M&ID=214		22 (0.02%)	22 (0.02%)	00:01:39	1 (0.00%)	100.00%	18.18%	\$0.00 (0.00%)
261.	/waukesha-county-emergency-rental-assistance-program		24 (0.02%)	22 (0.02%)	00:00:29	18 (0.03%)	83.33%	75.00%	\$0.00 (0.00%)
262.	/plan-commission-meetings-and-agendas?Type=M&ID=216		28 (0.02%)	21 (0.02%)	00:00:54	1 (0.00%)	100.00%	14.29%	\$0.00 (0.00%)
263.	/adopt-a-drain-program		25 (0.02%)	20 (0.02%)	00:00:50	0 (0.00%)	0.00%	8.00%	\$0.00 (0.00%)
264.	/agendas-meetings/		22 (0.02%)	20 (0.02%)	00:00:18	20 (0.04%)	0.00%	4.55%	\$0.00 (0.00%)
265.	/east-wisconsin-avenue-construction-project-update-10312022		24 (0.02%)	20 (0.02%)	00:00:36	0 (0.00%)	0.00%	16.67%	\$0.00 (0.00%)
266.	/in-person-absentee-voting-800-am-to-430-pm-2022-10-31		29 (0.02%)	20 (0.02%)	00:00:47	3 (0.01%)	66.67%	24.14%	\$0.00 (0.00%)
267.	/police-commission-meetings-and-agendas?Type=A&ID=232		24 (0.02%)	20 (0.02%)	00:00:12	1 (0.00%)	100.00%	16.67%	\$0.00 (0.00%)
268.	/public-works-safety-committee-meetings-and-agendas?Type=A&ID=239		26 (0.02%)	20 (0.02%)	00:01:13	7 (0.01%)	100.00%	30.77%	\$0.00 (0.00%)
269.	/stump-grinding-project-update		20 (0.01%)	20 (0.02%)	00:00:33	0 (0.00%)	0.00%	20.00%	\$0.00 (0.00%)
270.	/village-board-meetings-and-agendas?Type=D&ID=247		26 (0.02%)	20 (0.02%)	00:00:37	0 (0.00%)	0.00%	34.62%	\$0.00 (0.00%)
271.	/village-board-meetings-and-agendas?Type=M&ID=213		28 (0.02%)	20 (0.02%)	00:02:23	1 (0.00%)	100.00%	10.71%	\$0.00 (0.00%)
272.	/village-board-meetings-and-agendas?Type=M&ID=217		27 (0.02%)	20 (0.02%)	00:01:06	1 (0.00%)	100.00%	14.81%	\$0.00 (0.00%)
273.	/village-board-meetings-and-agendas?Type=M&ID=266		24 (0.02%)	20 (0.02%)	00:01:30	4 (0.01%)	100.00%	25.00%	\$0.00 (0.00%)
274.	/1st-round-leaf-collection-leaves-out-by-7-am-october-24th-2022-10-24		24 (0.02%)	19 (0.02%)	00:00:58	4 (0.01%)	50.00%	33.33%	\$0.00 (0.00%)
275.	/2022-fall-election-2022-11-08		23 (0.02%)	19 (0.02%)	00:01:43	2 (0.00%)	100.00%	69.57%	\$0.00 (0.00%)
276.	/Events/EditEvent.aspx?mid=1586&pageid=957		180 (0.13%)	19 (0.02%)	00:00:47	0 (0.00%)	0.00%	0.00%	\$0.00 (0.00%)
277.	/jbuddenhagen@villageofpewaukee.com		22 (0.02%)	19 (0.02%)	00:00:03	0 (0.00%)	0.00%	4.55%	\$0.00 (0.00%)
278.	/joint-review-board-meetings-and-agendas?Type=A&ID=237		31 (0.02%)	19 (0.02%)	00:00:20	0 (0.00%)	0.00%	12.90%	\$0.00 (0.00%)
279.	/plan-commission-meetings-and-agendas?Type=D&ID=229		33 (0.02%)	19 (0.02%)	00:02:30	6 (0.01%)	33.33%	30.30%	\$0.00 (0.00%)
280.	/plan-commission-meetings-and-agendas?Type=M&ID=220		25 (0.02%)	19 (0.02%)	00:01:31	1 (0.00%)	100.00%	32.00%	\$0.00 (0.00%)
281.	/plan-commission-meetings-and-agendas?Type=M&ID=236		22 (0.02%)	19 (0.02%)	00:03:38	4 (0.01%)	100.00%	18.18%	\$0.00 (0.00%)
282.	/village-board-meetings-and-agendas?Type=D&ID=217		26 (0.02%)	19 (0.02%)	00:02:34	4 (0.01%)	75.00%	26.92%	\$0.00 (0.00%)

283.	/village-board-meetings-and-agendas?Type=D&ID=263		30 <small>(0.02%)</small>	19 <small>(0.02%)</small>	00:00:07	7 <small>(0.01%)</small>	100.00%	36.67%	\$0.00 <small>(0.00%)</small>
284.	/village-board-meetings-and-agendas?Type=M&ID=225		23 <small>(0.02%)</small>	19 <small>(0.02%)</small>	00:02:10	1 <small>(0.00%)</small>	100.00%	17.39%	\$0.00 <small>(0.00%)</small>
285.	/Blog/ViewArchive.aspx?month=1&year=2022&pageid=1098&mid=2045		20 <small>(0.01%)</small>	18 <small>(0.02%)</small>	00:00:18	0 <small>(0.00%)</small>	0.00%	20.00%	\$0.00 <small>(0.00%)</small>
286.	/Data/Sites/38/media/for-residents/dpw/recycling-calendar.pdf		19 <small>(0.01%)</small>	18 <small>(0.02%)</small>	00:00:15	17 <small>(0.03%)</small>	17.65%	21.05%	\$0.00 <small>(0.00%)</small>
287.	/Data/Sites/38/media/planning-and-development/vop-comprehensive-plan-digital-copy-in-entirety.pdf		22 <small>(0.02%)</small>	18 <small>(0.02%)</small>	00:00:25	1 <small>(0.00%)</small>	0.00%	4.55%	\$0.00 <small>(0.00%)</small>
288.	/plan-commission-meetings-and-agendas?Edit=Y&ID=216		41 <small>(0.03%)</small>	18 <small>(0.02%)</small>	00:05:24	0 <small>(0.00%)</small>	0.00%	9.76%	\$0.00 <small>(0.00%)</small>
289.	/plan-commission-meetings-and-agendas?Type=A&ID=210		20 <small>(0.01%)</small>	18 <small>(0.02%)</small>	00:00:19	0 <small>(0.00%)</small>	0.00%	20.00%	\$0.00 <small>(0.00%)</small>
290.	/police-commission-meetings-and-agendas?Type=A&ID=221		20 <small>(0.01%)</small>	18 <small>(0.02%)</small>	00:00:18	0 <small>(0.00%)</small>	0.00%	15.00%	\$0.00 <small>(0.00%)</small>
291.	/returning-absentee-ballots-		26 <small>(0.02%)</small>	18 <small>(0.02%)</small>	00:00:20	0 <small>(0.00%)</small>	0.00%	11.54%	\$0.00 <small>(0.00%)</small>
292.	/village-board-meetings-and-agendas?Type=D&ID=235		22 <small>(0.02%)</small>	18 <small>(0.02%)</small>	00:00:53	2 <small>(0.00%)</small>	0.00%	45.45%	\$0.00 <small>(0.00%)</small>
293.	/village-board-meetings-and-agendas?Type=M&ID=208		23 <small>(0.02%)</small>	18 <small>(0.02%)</small>	00:01:09	1 <small>(0.00%)</small>	100.00%	13.04%	\$0.00 <small>(0.00%)</small>
294.	/Data/Sites/38/media/for-residents/election/voter-ward-map.pdf		21 <small>(0.02%)</small>	17 <small>(0.02%)</small>	00:00:09	4 <small>(0.01%)</small>	50.00%	28.57%	\$0.00 <small>(0.00%)</small>
295.	/labor-day-2021-09-06		19 <small>(0.01%)</small>	17 <small>(0.02%)</small>	00:00:20	17 <small>(0.03%)</small>	64.71%	68.42%	\$0.00 <small>(0.00%)</small>
296.	/search-results?ustems=Fireworks		21 <small>(0.02%)</small>	17 <small>(0.02%)</small>	00:00:28	0 <small>(0.00%)</small>	0.00%	33.33%	\$0.00 <small>(0.00%)</small>
297.	/search-results?ustems=Police		20 <small>(0.01%)</small>	17 <small>(0.02%)</small>	00:02:43	0 <small>(0.00%)</small>	0.00%	25.00%	\$0.00 <small>(0.00%)</small>
298.	/search-results?ustems=trick or treat		19 <small>(0.01%)</small>	17 <small>(0.02%)</small>	00:00:13	0 <small>(0.00%)</small>	0.00%	21.05%	\$0.00 <small>(0.00%)</small>
299.	/village-board-meetings-and-agendas?Type=A&ID=208		20 <small>(0.01%)</small>	17 <small>(0.02%)</small>	00:00:16	6 <small>(0.01%)</small>	100.00%	35.00%	\$0.00 <small>(0.00%)</small>
300.	/village-board-meetings-and-agendas?Type=D&ID=248		28 <small>(0.02%)</small>	17 <small>(0.02%)</small>	00:02:52	0 <small>(0.00%)</small>	0.00%	28.57%	\$0.00 <small>(0.00%)</small>
301.	/village-board-meetings-and-agendas?Type=D&ID=256		22 <small>(0.02%)</small>	17 <small>(0.02%)</small>	00:01:51	1 <small>(0.00%)</small>	100.00%	54.55%	\$0.00 <small>(0.00%)</small>
302.	/village-board-meetings-and-agendas?Type=M&ID=268		25 <small>(0.02%)</small>	17 <small>(0.02%)</small>	00:01:36	4 <small>(0.01%)</small>	100.00%	28.00%	\$0.00 <small>(0.00%)</small>
303.	/Admin/PageManager.aspx		29 <small>(0.02%)</small>	16 <small>(0.02%)</small>	00:00:22	0 <small>(0.00%)</small>	0.00%	0.00%	\$0.00 <small>(0.00%)</small>
304.	/Blog/ViewArchive.aspx?month=7&year=2022&pageid=1098&mid=2045		17 <small>(0.01%)</small>	16 <small>(0.02%)</small>	00:00:16	1 <small>(0.00%)</small>	0.00%	5.88%	\$0.00 <small>(0.00%)</small>
305.	/plan-commission-meetings-and-agendas?STATUS=SE&ID=216		37 <small>(0.03%)</small>	16 <small>(0.02%)</small>	00:01:02	4 <small>(0.01%)</small>	0.00%	8.11%	\$0.00 <small>(0.00%)</small>
306.	/plan-commission-meetings-and-agendas?Type=M&ID=246		17 <small>(0.01%)</small>	16 <small>(0.02%)</small>	00:01:42	1 <small>(0.00%)</small>	100.00%	29.41%	\$0.00 <small>(0.00%)</small>
307.	/police-commission-meetings-and-agendas?Type=A&ID=276		19 <small>(0.01%)</small>	16 <small>(0.02%)</small>	00:00:10	7 <small>(0.01%)</small>	100.00%	52.63%	\$0.00 <small>(0.00%)</small>
308.	/search-results?ustems=recycling		19 <small>(0.01%)</small>	16 <small>(0.02%)</small>	00:00:13	0 <small>(0.00%)</small>	0.00%	5.26%	\$0.00 <small>(0.00%)</small>
309.	/thanksgiving-day-2022-11-24		16 <small>(0.01%)</small>	16 <small>(0.02%)</small>	00:00:00	16 <small>(0.03%)</small>	100.00%	100.00%	\$0.00 <small>(0.00%)</small>
310.	/village-board-meetings-and-agendas?Type=M&ID=261		25 <small>(0.02%)</small>	16 <small>(0.02%)</small>	00:01:30	3 <small>(0.01%)</small>	66.67%	20.00%	\$0.00 <small>(0.00%)</small>
311.	/zoning-board-of-appeals-meetings-and-agendas?Type=A&ID=186		17 <small>(0.01%)</small>	16 <small>(0.02%)</small>	00:00:20	0 <small>(0.00%)</small>	0.00%	5.88%	\$0.00 <small>(0.00%)</small>
312.	/Data/Sites/38/media/for-residents/election/type-a-notice.pdf		21 <small>(0.02%)</small>	15 <small>(0.01%)</small>	00:01:36	0 <small>(0.00%)</small>	0.00%	19.05%	\$0.00 <small>(0.00%)</small>
313.	/Events/MonthView.aspx?pageid=957&mid=1586&visdate1586=2023-02-01T00:00:00		66 <small>(0.05%)</small>	15 <small>(0.01%)</small>	00:00:04	0 <small>(0.00%)</small>	0.00%	1.52%	\$0.00 <small>(0.00%)</small>
314.	/joint-review-board-meetings-and-agendas?Type=A&ID=224		26 <small>(0.02%)</small>	15 <small>(0.01%)</small>	00:01:16	5 <small>(0.01%)</small>	60.00%	23.08%	\$0.00 <small>(0.00%)</small>
315.	/plan-commission-meetings-and-agendas?Edit=Y&ID=220		18 <small>(0.01%)</small>	15 <small>(0.01%)</small>	00:00:39	0 <small>(0.00%)</small>	0.00%	16.67%	\$0.00 <small>(0.00%)</small>
316.	/plan-commission-meetings-and-agendas?Type=A&ID=203		17 <small>(0.01%)</small>	15 <small>(0.01%)</small>	00:02:05	2 <small>(0.00%)</small>	100.00%	41.18%	\$0.00 <small>(0.00%)</small>
317.	/police-commission-meetings-and-agendas?Type=A&ID=218		16 <small>(0.01%)</small>	15 <small>(0.01%)</small>	00:00:27	1 <small>(0.00%)</small>	100.00%	18.75%	\$0.00 <small>(0.00%)</small>
318.	/police-commission-meetings-and-agendas?Type=A&ID=231		23 <small>(0.02%)</small>	15 <small>(0.01%)</small>	00:00:13	1 <small>(0.00%)</small>	100.00%	8.70%	\$0.00 <small>(0.00%)</small>
319.	/SuperFlexi/Edit.aspx?pageid=1042&mid=1795&itemid=1307		25 <small>(0.02%)</small>	15 <small>(0.01%)</small>	00:01:22	0 <small>(0.00%)</small>	0.00%	0.00%	\$0.00 <small>(0.00%)</small>
320.	/zoning-board-of-appeals-meetings-and-agendas?Type=D&ID=273		15 <small>(0.01%)</small>	15 <small>(0.01%)</small>	00:04:11	11 <small>(0.02%)</small>	100.00%	86.67%	\$0.00 <small>(0.00%)</small>
321.	/?Type=A&ID=135		16 <small>(0.01%)</small>	14 <small>(0.01%)</small>	00:02:11	7 <small>(0.01%)</small>	71.43%	43.75%	\$0.00 <small>(0.00%)</small>
322.	/Blog/ViewArchive.aspx?month=12&year=2021&pageid=1098&mid=2045		16 <small>(0.01%)</small>	14 <small>(0.01%)</small>	00:00:17	0 <small>(0.00%)</small>	0.00%	12.50%	\$0.00 <small>(0.00%)</small>
323.	/Blog/ViewArchive.aspx?month=4&year=2022&pageid=1098&mid=2045		17 <small>(0.01%)</small>	14 <small>(0.01%)</small>	00:00:14	0 <small>(0.00%)</small>	0.00%	11.76%	\$0.00 <small>(0.00%)</small>
324.	/Blog/ViewArchive.aspx?month=8&year=2022&pageid=1098&mid=2045		18 <small>(0.01%)</small>	14 <small>(0.01%)</small>	00:00:39	1 <small>(0.00%)</small>	100.00%	27.78%	\$0.00 <small>(0.00%)</small>

325.	/Curbside-Garbage-and-Recycling-CollectionIf		16 (0.01%)	14 (0.01%)	00:00:37	13 (0.02%)	61.54%	62.50%	\$0.00 (0.00%)
326.	/Events/MonthView.aspx?pageid=957&mid=1586&visdate1586=2023-03-01T00:00:00		58 (0.04%)	14 (0.01%)	00:00:03	1 (0.00%)	100.00%	3.45%	\$0.00 (0.00%)
327.	/in-person-absentee-voting-800-am-to-500-pm-2022-11-04		14 (0.01%)	14 (0.01%)	00:00:23	3 (0.01%)	100.00%	71.43%	\$0.00 (0.00%)
328.	/plan-commission-meetings-and-agendas?Type=M&ID=229		14 (0.01%)	14 (0.01%)	00:02:40	1 (0.00%)	100.00%	14.29%	\$0.00 (0.00%)
329.	/plan-commission-meetings-and-agendas?Type=M&ID=267		14 (0.01%)	14 (0.01%)	00:01:15	2 (0.00%)	100.00%	14.29%	\$0.00 (0.00%)
330.	/police-commission-meetings-and-agendas?Type=D&ID=265		21 (0.02%)	14 (0.01%)	00:00:10	6 (0.01%)	100.00%	33.33%	\$0.00 (0.00%)
331.	/public-works-safety-committee-meetings-and-agendas?Type=A&ID=211		20 (0.01%)	14 (0.01%)	00:00:25	0 (0.00%)	0.00%	10.00%	\$0.00 (0.00%)
332.	/search-results?usterm=fence		16 (0.01%)	14 (0.01%)	00:00:17	0 (0.00%)	0.00%	12.50%	\$0.00 (0.00%)
333.	/search-results?usterm=ordinances		15 (0.01%)	14 (0.01%)	00:00:24	0 (0.00%)	0.00%	6.67%	\$0.00 (0.00%)
334.	/search-results?usterm=parking		22 (0.02%)	14 (0.01%)	00:00:50	0 (0.00%)	0.00%	4.55%	\$0.00 (0.00%)
335.	/search-results?usterm=sample ballot		15 (0.01%)	14 (0.01%)	00:00:14	1 (0.00%)	0.00%	46.67%	\$0.00 (0.00%)
336.	/search-results?usterm=trash		14 (0.01%)	14 (0.01%)	00:00:16	1 (0.00%)	0.00%	0.00%	\$0.00 (0.00%)
337.	/search-results?usterm=Trash		14 (0.01%)	14 (0.01%)	00:00:08	0 (0.00%)	0.00%	0.00%	\$0.00 (0.00%)
338.	/search-results?usterm=voting		16 (0.01%)	14 (0.01%)	00:00:22	0 (0.00%)	0.00%	18.75%	\$0.00 (0.00%)
339.	/village-board-meetings-and-agendas?Edit=Y&ID=223		15 (0.01%)	14 (0.01%)	00:03:32	0 (0.00%)	0.00%	13.33%	\$0.00 (0.00%)
340.	/village-board-meetings-and-agendas?Type=A&ID=213		14 (0.01%)	14 (0.01%)	00:00:34	0 (0.00%)	0.00%	7.14%	\$0.00 (0.00%)
341.	/1st-round-leaf-collection-leaves-out-by-7-am-october-24th-2022-10-31		15 (0.01%)	13 (0.01%)	00:00:31	0 (0.00%)	0.00%	13.33%	\$0.00 (0.00%)
342.	/Blog/ViewArchive.aspx?month=5&year=2022&pageid=1098&mid=2045		16 (0.01%)	13 (0.01%)	00:00:16	1 (0.00%)	100.00%	25.00%	\$0.00 (0.00%)
343.	/HtmlEdit.aspx?mid=1785&pageid=1060		16 (0.01%)	13 (0.01%)	00:01:28	0 (0.00%)	0.00%	0.00%	\$0.00 (0.00%)
344.	/plan-commission-meetings-and-agendas?New=Y		19 (0.01%)	13 (0.01%)	00:02:41	1 (0.00%)	0.00%	0.00%	\$0.00 (0.00%)
345.	/plan-commission-meetings-and-agendas?Type=A&ID=206		16 (0.01%)	13 (0.01%)	00:00:54	1 (0.00%)	100.00%	12.50%	\$0.00 (0.00%)
346.	/search-results?usterm=dog license		14 (0.01%)	13 (0.01%)	00:00:11	1 (0.00%)	0.00%	7.14%	\$0.00 (0.00%)
347.	/search-results?usterm=Yard waste		15 (0.01%)	13 (0.01%)	00:00:13	0 (0.00%)	0.00%	0.00%	\$0.00 (0.00%)
348.	/village-board-meetings-and-agendas?Edit=Y&ID=248		16 (0.01%)	13 (0.01%)	00:03:28	2 (0.00%)	0.00%	6.25%	\$0.00 (0.00%)
349.	/village-board-meetings-and-agendas?Type=M&ID=180		17 (0.01%)	13 (0.01%)	00:02:37	2 (0.00%)	100.00%	29.41%	\$0.00 (0.00%)
350.	/?Type=M&ID=135		15 (0.01%)	12 (0.01%)	00:00:19	0 (0.00%)	0.00%	20.00%	\$0.00 (0.00%)
351.	/2022-fall-primary-election-2022-08-09		14 (0.01%)	12 (0.01%)	00:01:55	0 (0.00%)	0.00%	64.29%	\$0.00 (0.00%)
352.	/7-pm-village-board-meeting--2022-10-04		14 (0.01%)	12 (0.01%)	00:00:18	2 (0.00%)	0.00%	21.43%	\$0.00 (0.00%)
353.	/Blog/ViewArchive.aspx?month=9&year=2022&pageid=1098&mid=2045		13 (0.01%)	12 (0.01%)	00:00:13	1 (0.00%)	100.00%	15.38%	\$0.00 (0.00%)
354.	/board-of-review-meetings-and-agendas?Type=D&ID=233		15 (0.01%)	12 (0.01%)	00:02:42	1 (0.00%)	0.00%	26.67%	\$0.00 (0.00%)
355.	/board-of-review-meetings-and-agendas?Type=M&ID=233		16 (0.01%)	12 (0.01%)	00:02:35	6 (0.01%)	100.00%	56.25%	\$0.00 (0.00%)
356.	/christmas-tree-pu-starts--trees-must-be-out-by-7-am-2020-12-21		12 (0.01%)	12 (0.01%)	00:01:58	10 (0.02%)	50.00%	58.33%	\$0.00 (0.00%)
357.	/Data/Sites/38/media/for-residents/forms/row-permit-application.pdf		17 (0.01%)	12 (0.01%)	00:00:12	0 (0.00%)	0.00%	0.00%	\$0.00 (0.00%)
358.	/economic-profile		16 (0.01%)	12 (0.01%)	00:00:41	3 (0.01%)	66.67%	37.50%	\$0.00 (0.00%)
359.	/Events/MonthView.aspx?pageid=957&mid=1586&visdate1586=2023-04-01T00:00:00		55 (0.04%)	12 (0.01%)	00:00:05	0 (0.00%)	0.00%	3.64%	\$0.00 (0.00%)
360.	/HtmlEdit.aspx?mid=1803&pageid=1070		14 (0.01%)	12 (0.01%)	00:03:26	0 (0.00%)	0.00%	7.14%	\$0.00 (0.00%)
361.	/pewaukeelakepatrol.html		12 (0.01%)	12 (0.01%)	00:00:11	12 (0.02%)	66.67%	66.67%	\$0.00 (0.00%)
362.	/plan-commission-meetings-and-agendas?Type=D&ID=236		19 (0.01%)	12 (0.01%)	00:03:00	2 (0.00%)	0.00%	31.58%	\$0.00 (0.00%)
363.	/plan-commission-meetings-and-agendas?Type=D&ID=250		25 (0.02%)	12 (0.01%)	00:01:48	0 (0.00%)	0.00%	20.00%	\$0.00 (0.00%)
364.	/plan-commission-meetings-and-agendas?Type=D&ID=257		32 (0.02%)	12 (0.01%)	00:02:02	3 (0.01%)	66.67%	25.00%	\$0.00 (0.00%)
365.	/police-commission-meetings-and-agendas?Type=A&ID=272		13 (0.01%)	12 (0.01%)	00:00:08	6 (0.01%)	100.00%	61.54%	\$0.00 (0.00%)
366.	/search-results?usterm=fireworks		21 (0.02%)	12 (0.01%)	00:00:32	0 (0.00%)	0.00%	14.29%	\$0.00 (0.00%)
367.	/search-results?usterm=Fireworks		15 (0.01%)	12 (0.01%)	00:00:55	0 (0.00%)	0.00%	20.00%	\$0.00 (0.00%)

	/search-results?usterm=Track or treat		13 (0.01%)	12 (0.01%)	00:00:53	0 (0.00%)	0.00%	20.00%	\$0.00 (0.00%)
368.	/search-results?usterm=Vote		16 (0.01%)	12 (0.01%)	00:02:11	0 (0.00%)	0.00%	43.75%	\$0.00 (0.00%)
369.	/search-results?usterm=Voting		14 (0.01%)	12 (0.01%)	00:00:17	0 (0.00%)	0.00%	14.29%	\$0.00 (0.00%)
370.	/village-board-meetings-and-agendas?Edit=Y&ID=244		18 (0.01%)	12 (0.01%)	00:01:20	0 (0.00%)	0.00%	0.00%	\$0.00 (0.00%)
371.	/village-board-meetings-and-agendas?Type=D&ID=219		22 (0.02%)	12 (0.01%)	00:00:37	0 (0.00%)	0.00%	22.73%	\$0.00 (0.00%)
372.	/village-board-meetings-and-agendas?Type=D&ID=223		17 (0.01%)	12 (0.01%)	00:00:31	0 (0.00%)	0.00%	29.41%	\$0.00 (0.00%)
373.	/village-board-meetings-and-agendas?Type=D&ID=225		21 (0.02%)	12 (0.01%)	00:02:49	0 (0.00%)	0.00%	23.81%	\$0.00 (0.00%)
374.	/village-board-meetings-and-agendas?Type=D&ID=238		17 (0.01%)	12 (0.01%)	00:02:43	0 (0.00%)	0.00%	29.41%	\$0.00 (0.00%)
375.	/village-board-meetings-and-agendas?Type=M&ID=134		14 (0.01%)	12 (0.01%)	00:02:29	6 (0.01%)	50.00%	42.86%	\$0.00 (0.00%)
376.	/village-board-meetings-and-agendas?Type=M&ID=202		13 (0.01%)	12 (0.01%)	00:01:02	1 (0.00%)	100.00%	30.77%	\$0.00 (0.00%)
377.	/7-pm-village-board-meeting--2022-03-15		12 (0.01%)	11 (0.01%)	00:00:09	0 (0.00%)	0.00%	8.33%	\$0.00 (0.00%)
378.	/Blog/ViewArchive.aspx?month=10&year=2022&pageid=1098&mid=2045		12 (0.01%)	11 (0.01%)	00:00:27	0 (0.00%)	0.00%	0.00%	\$0.00 (0.00%)
379.	/faq-2		11 (0.01%)	11 (0.01%)	00:00:00	11 (0.02%)	100.00%	100.00%	\$0.00 (0.00%)
380.	/pewaukee-lake-advisory-committe-meetings-and-agendas?Type=A&ID=207		13 (0.01%)	11 (0.01%)	00:00:26	0 (0.00%)	0.00%	7.69%	\$0.00 (0.00%)
381.	/plan-commission-meetings-and-agendas?Edit=Y&ID=229		38 (0.03%)	11 (0.01%)	00:03:42	1 (0.00%)	0.00%	5.26%	\$0.00 (0.00%)
382.	/plan-commission-meetings-and-agendas?Type=A&ID=194		16 (0.01%)	11 (0.01%)	00:00:43	0 (0.00%)	0.00%	12.50%	\$0.00 (0.00%)
383.	/police-commission-meetings-and-agendas?Type=M&ID=198		12 (0.01%)	11 (0.01%)	00:00:37	3 (0.01%)	66.67%	33.33%	\$0.00 (0.00%)
384.	/police-commission-meetings-and-agendas?Type=M&ID=221		12 (0.01%)	11 (0.01%)	00:00:42	2 (0.00%)	100.00%	25.00%	\$0.00 (0.00%)
385.	/search-results?usterm=jobs		14 (0.01%)	11 (0.01%)	00:00:11	0 (0.00%)	0.00%	21.43%	\$0.00 (0.00%)
386.	/search-results?usterm=pay bill		14 (0.01%)	11 (0.01%)	00:00:11	0 (0.00%)	0.00%	0.00%	\$0.00 (0.00%)
387.	/village-board-meetings-and-agendas?Edit=Y&ID=230		19 (0.01%)	11 (0.01%)	00:02:59	0 (0.00%)	0.00%	5.26%	\$0.00 (0.00%)
388.	/village-board-meetings-and-agendas?Edit=Y&ID=258		14 (0.01%)	11 (0.01%)	00:03:55	0 (0.00%)	0.00%	14.29%	\$0.00 (0.00%)
389.	/village-board-meetings-and-agendas?STATUS=SE&ID=223		12 (0.01%)	11 (0.01%)	00:00:05	2 (0.00%)	50.00%	25.00%	\$0.00 (0.00%)
390.	/village-board-meetings-and-agendas?STATUS=SE&ID=244		15 (0.01%)	11 (0.01%)	00:02:18	0 (0.00%)	0.00%	13.33%	\$0.00 (0.00%)
391.	/village-board-meetings-and-agendas?Type=M&ID=200		14 (0.01%)	11 (0.01%)	00:01:29	1 (0.00%)	100.00%	28.57%	\$0.00 (0.00%)
392.	/village-board-meetings-and-agendas?Type=M&ID=205		15 (0.01%)	11 (0.01%)	00:00:55	1 (0.00%)	100.00%	26.67%	\$0.00 (0.00%)
393.	/_custom/_admin/listserv/user/sub-unsub.asp?Listserv=villagepewaukee		10 (0.01%)	10 (0.01%)	00:00:28	0 (0.00%)	0.00%	90.00%	\$0.00 (0.00%)
394.	/7-pm-village-board-meeting--2022-08-16		14 (0.01%)	10 (0.01%)	00:00:14	0 (0.00%)	0.00%	7.14%	\$0.00 (0.00%)
395.	/7-pm-village-board-meeting--2022-09-06		12 (0.01%)	10 (0.01%)	00:00:09	0 (0.00%)	0.00%	8.33%	\$0.00 (0.00%)
396.	/Blog/ViewArchive.aspx?month=6&year=2022&pageid=1098&mid=2045		11 (0.01%)	10 (0.01%)	00:00:08	0 (0.00%)	0.00%	36.36%	\$0.00 (0.00%)
397.	/board-of-review-meetings-and-agendas?Edit=Y&ID=233		13 (0.01%)	10 (0.01%)	00:00:56	0 (0.00%)	0.00%	7.69%	\$0.00 (0.00%)
398.	/Events/MonthView.aspx?pageid=957&mid=1586		10 (0.01%)	10 (0.01%)	00:00:16	1 (0.00%)	100.00%	30.00%	\$0.00 (0.00%)
399.	/Events/MonthView.aspx?pageid=957&mid=1586&visdate1586=2023-05-01T00:00:00		50 (0.04%)	10 (0.01%)	00:00:05	0 (0.00%)	0.00%	2.00%	\$0.00 (0.00%)
400.	/finances/		10 (0.01%)	10 (0.01%)	00:00:00	10 (0.02%)	100.00%	100.00%	\$0.00 (0.00%)
401.	/links/		11 (0.01%)	10 (0.01%)	00:00:11	9 (0.02%)	66.67%	72.73%	\$0.00 (0.00%)
402.	/MemberList.aspx		24 (0.02%)	10 (0.01%)	00:00:35	1 (0.00%)	0.00%	8.33%	\$0.00 (0.00%)
403.	/pewaukee-lake-harvesting-permit		14 (0.01%)	10 (0.01%)	00:01:38	0 (0.00%)	0.00%	14.29%	\$0.00 (0.00%)
404.	/plan-commission-meetings-and-agendas?Type=D&ID=216		13 (0.01%)	10 (0.01%)	00:02:38	1 (0.00%)	100.00%	46.15%	\$0.00 (0.00%)
405.	/search-results?usterm=budget		12 (0.01%)	10 (0.01%)	00:00:12	0 (0.00%)	0.00%	41.67%	\$0.00 (0.00%)
406.	/search-results?usterm=building permit		10 (0.01%)	10 (0.01%)	00:00:15	0 (0.00%)	0.00%	10.00%	\$0.00 (0.00%)
407.	/search-results?usterm=Halloween		12 (0.01%)	10 (0.01%)	00:00:15	1 (0.00%)	100.00%	25.00%	\$0.00 (0.00%)
408.	/search-results?usterm=plumbing permit		12 (0.01%)	10 (0.01%)	00:00:13	0 (0.00%)	0.00%	16.67%	\$0.00 (0.00%)
409.	/search-results?usterm=water		11 (0.01%)	10 (0.01%)	00:01:15	0 (0.00%)	0.00%	0.00%	\$0.00 (0.00%)

		(0.01%)	(0.01%)	(0.00%)	(0.00%)			
410.	/spring-brush-pick-up-weather-permitting-2022-04-18	 19 (0.01%)	10 (0.01%)	00:00:37	1 (0.00%)	0.00%	26.32%	\$0.00 (0.00%)
411.	/village-board-meetings-and-agendas?Edit=Y&ID=217	 42 (0.03%)	10 (0.01%)	00:05:24	0 (0.00%)	0.00%	4.76%	\$0.00 (0.00%)
412.	/village-board-meetings-and-agendas?Edit=Y&ID=219	 16 (0.01%)	10 (0.01%)	00:04:58	1 (0.00%)	0.00%	12.50%	\$0.00 (0.00%)
413.	/village-board-meetings-and-agendas?Edit=Y&ID=235	 13 (0.01%)	10 (0.01%)	00:06:51	0 (0.00%)	0.00%	15.38%	\$0.00 (0.00%)
414.	/village-board-meetings-and-agendas?Edit=Y&ID=238	 16 (0.01%)	10 (0.01%)	00:04:07	0 (0.00%)	0.00%	6.25%	\$0.00 (0.00%)
415.	/village-board-meetings-and-agendas?Edit=Y&ID=256	 14 (0.01%)	10 (0.01%)	00:04:13	0 (0.00%)	0.00%	0.00%	\$0.00 (0.00%)
416.	/village-board-meetings-and-agendas?STATUS=SE&ID=258	 13 (0.01%)	10 (0.01%)	00:00:03	2 (0.00%)	0.00%	15.38%	\$0.00 (0.00%)
417.	/village-board-meetings-and-agendas?Type=A&ID=204	 14 (0.01%)	10 (0.01%)	00:00:09	0 (0.00%)	0.00%	0.00%	\$0.00 (0.00%)
418.	/village-board-meetings-and-agendas?Type=D&ID=258	 11 (0.01%)	10 (0.01%)	00:04:47	0 (0.00%)	0.00%	45.45%	\$0.00 (0.00%)
419.	/village-board-meetings-and-agendas?Type=M&ID=143	 11 (0.01%)	10 (0.01%)	00:15:41	5 (0.01%)	60.00%	72.73%	\$0.00 (0.00%)
420.	/village-board-meetings-and-agendas?Type=M&ID=183	 10 (0.01%)	10 (0.01%)	00:01:27	1 (0.00%)	100.00%	20.00%	\$0.00 (0.00%)
421.	/village-board-meetings-and-agendas?Type=M&ID=201	 12 (0.01%)	10 (0.01%)	00:01:59	2 (0.00%)	50.00%	16.67%	\$0.00 (0.00%)
422.	/7-pm-village-board-meeting--2022-06-07	 11 (0.01%)	9 (0.01%)	00:00:17	0 (0.00%)	0.00%	9.09%	\$0.00 (0.00%)
423.	/7-pm-village-board-meeting--2022-09-20	 18 (0.01%)	9 (0.01%)	00:00:18	0 (0.00%)	0.00%	16.67%	\$0.00 (0.00%)
424.	/7-pm-village-board-meeting-via-zoom-2022-02-01	 11 (0.01%)	9 (0.01%)	00:00:11	1 (0.00%)	100.00%	9.09%	\$0.00 (0.00%)
425.	/curbside-garbage-and-recycling-collection	 9 (0.01%)	9 (0.01%)	00:00:00	9 (0.02%)	100.00%	100.00%	\$0.00 (0.00%)
426.	/HtmlEdit.aspx?mid=1576&pageid=940	 21 (0.02%)	9 (0.01%)	00:00:28	0 (0.00%)	0.00%	4.76%	\$0.00 (0.00%)
427.	/HtmlEdit.aspx?mid=1754&pageid=1038	 18 (0.01%)	9 (0.01%)	00:01:03	0 (0.00%)	0.00%	0.00%	\$0.00 (0.00%)
428.	/HtmlEdit.aspx?mid=1755&pageid=1046	 10 (0.01%)	9 (0.01%)	00:02:34	0 (0.00%)	0.00%	0.00%	\$0.00 (0.00%)
429.	/joint-review-board-meetings-and-agendas?Type=D&ID=251	 11 (0.01%)	9 (0.01%)	00:02:43	0 (0.00%)	0.00%	45.45%	\$0.00 (0.00%)
430.	/plan-commission-meetings-and-agendas?STATUS=SE&ID=229	 31 (0.02%)	9 (0.01%)	00:01:20	1 (0.00%)	0.00%	6.45%	\$0.00 (0.00%)
431.	/plan-commission-meetings-and-agendas?Type=A&ID=176	 10 (0.01%)	9 (0.01%)	00:01:50	2 (0.00%)	100.00%	20.00%	\$0.00 (0.00%)
432.	/plan-commission-meetings-and-agendas?Type=A&ID=197	 14 (0.01%)	9 (0.01%)	00:00:12	0 (0.00%)	0.00%	7.14%	\$0.00 (0.00%)
433.	/plan-commission-meetings-and-agendas?Type=M&ID=206	 11 (0.01%)	9 (0.01%)	00:02:38	1 (0.00%)	100.00%	27.27%	\$0.00 (0.00%)
434.	/police-commission-meetings-and-agendas?New=Y	 11 (0.01%)	9 (0.01%)	00:01:09	0 (0.00%)	0.00%	0.00%	\$0.00 (0.00%)
435.	/search-results?ustems=Early voting	 10 (0.01%)	9 (0.01%)	00:00:23	1 (0.00%)	100.00%	20.00%	\$0.00 (0.00%)
436.	/search-results?ustems=employment	 14 (0.01%)	9 (0.01%)	00:00:10	0 (0.00%)	0.00%	14.29%	\$0.00 (0.00%)
437.	/search-results?ustems=Fence	 13 (0.01%)	9 (0.01%)	00:00:28	0 (0.00%)	0.00%	23.08%	\$0.00 (0.00%)
438.	/search-results?ustems=ordinance	 11 (0.01%)	9 (0.01%)	00:00:19	0 (0.00%)	0.00%	9.09%	\$0.00 (0.00%)
439.	/search-results?ustems=Overnight parking	 10 (0.01%)	9 (0.01%)	00:00:09	0 (0.00%)	0.00%	10.00%	\$0.00 (0.00%)
440.	/search-results?ustems=Sample ballot	 11 (0.01%)	9 (0.01%)	00:00:12	0 (0.00%)	0.00%	27.27%	\$0.00 (0.00%)
441.	/spring-brush-pick-up--2021-04-19	 10 (0.01%)	9 (0.01%)	00:01:13	7 (0.01%)	28.57%	30.00%	\$0.00 (0.00%)
442.	/village-board-meetings-and-agendas?Edit=Y&ID=243	 12 (0.01%)	9 (0.01%)	00:03:41	1 (0.00%)	0.00%	8.33%	\$0.00 (0.00%)
443.	/village-board-meetings-and-agendas?Edit=Y&ID=252	 14 (0.01%)	9 (0.01%)	00:02:57	0 (0.00%)	0.00%	7.14%	\$0.00 (0.00%)
444.	/village-board-meetings-and-agendas?STATUS=SE&ID=238	 13 (0.01%)	9 (0.01%)	00:00:42	1 (0.00%)	100.00%	23.08%	\$0.00 (0.00%)
445.	/village-board-meetings-and-agendas?Type=A&ID=143	 13 (0.01%)	9 (0.01%)	00:00:29	4 (0.01%)	0.00%	15.38%	\$0.00 (0.00%)
446.	/village-board-meetings-and-agendas?Type=A&ID=200	 9 (0.01%)	9 (0.01%)	00:00:13	0 (0.00%)	0.00%	11.11%	\$0.00 (0.00%)
447.	/village-board-meetings-and-agendas?Type=A&ID=202	 11 (0.01%)	9 (0.01%)	00:00:06	0 (0.00%)	0.00%	9.09%	\$0.00 (0.00%)
448.	/village-board-meetings-and-agendas?Type=A&ID=205	 10 (0.01%)	9 (0.01%)	00:02:31	0 (0.00%)	0.00%	0.00%	\$0.00 (0.00%)
449.	/village-board-meetings-and-agendas?Type=M&ID=188	 12 (0.01%)	9 (0.01%)	00:00:25	2 (0.00%)	100.00%	33.33%	\$0.00 (0.00%)
450.	/village-board-meetings-and-agendas?Type=M&ID=196	 9 (0.01%)	9 (0.01%)	00:01:48	1 (0.00%)	100.00%	11.11%	\$0.00 (0.00%)
451.	/village-board-meetings-and-agendas?Type=M&ID=204	 12 (0.01%)	9 (0.01%)	00:01:04	1 (0.00%)	100.00%	8.33%	\$0.00 (0.00%)

452.	/village-board-meetings-and-agendas?Type=M&ID=271		9 (0.01%)	9 (0.01%)	00:02:34	3 (0.01%)	100.00%	33.33%	\$0.00 (0.00%)
453.	/7-pm-plan-commission-meeting--2022-08-11		8 (0.01%)	8 (0.01%)	00:00:11	0 (0.00%)	0.00%	0.00%	\$0.00 (0.00%)
454.	/7-pm-village-board-meeting--2022-05-17		9 (0.01%)	8 (0.01%)	00:00:13	0 (0.00%)	0.00%	0.00%	\$0.00 (0.00%)
455.	/7-pm-village-board-meeting--2022-06-21		9 (0.01%)	8 (0.01%)	00:00:16	1 (0.00%)	0.00%	0.00%	\$0.00 (0.00%)
456.	/7-pm-village-board-meeting-via-zoom-2022-01-18		8 (0.01%)	8 (0.01%)	00:00:06	2 (0.00%)	100.00%	25.00%	\$0.00 (0.00%)
457.	/Events/MonthView.aspx?pageid=957&mid=1586&visdate1586=2023-06-01T00:00:00		41 (0.03%)	8 (0.01%)	00:00:05	0 (0.00%)	0.00%	0.00%	\$0.00 (0.00%)
458.	/Events/MonthView.aspx?pageid=957&mid=1586&visdate1586=2023-07-01T00:00:00		40 (0.03%)	8 (0.01%)	00:00:06	0 (0.00%)	0.00%	2.50%	\$0.00 (0.00%)
459.	/plan-commission-meetings-and-agendas?Edit=Y&ID=236		10 (0.01%)	8 (0.01%)	00:03:10	0 (0.00%)	0.00%	50.00%	\$0.00 (0.00%)
460.	/plan-commission-meetings-and-agendas?Type=M&ID=137		10 (0.01%)	8 (0.01%)	00:01:12	3 (0.01%)	100.00%	50.00%	\$0.00 (0.00%)
461.	/plan-commission-meetings-and-agendas?Type=M&ID=176		10 (0.01%)	8 (0.01%)	00:00:56	1 (0.00%)	100.00%	40.00%	\$0.00 (0.00%)
462.	/public-works-safety-committee-meetings-and-agendas?Type=D&ID=253		9 (0.01%)	8 (0.01%)	00:00:44	1 (0.00%)	100.00%	55.56%	\$0.00 (0.00%)
463.	/search-results?usterm=Ballot		13 (0.01%)	8 (0.01%)	00:00:35	0 (0.00%)	0.00%	7.69%	\$0.00 (0.00%)
464.	/search-results?usterm=election		10 (0.01%)	8 (0.01%)	00:00:18	0 (0.00%)	0.00%	0.00%	\$0.00 (0.00%)
465.	/search-results?usterm=Garbage pickup		12 (0.01%)	8 (0.01%)	00:00:46	0 (0.00%)	0.00%	25.00%	\$0.00 (0.00%)
466.	/search-results?usterm=permits		8 (0.01%)	8 (0.01%)	00:00:36	0 (0.00%)	0.00%	0.00%	\$0.00 (0.00%)
467.	/Secure/Login.aspx?returnurl=/Admin/AdminMenu.aspx		10 (0.01%)	8 (0.01%)	00:00:04	1 (0.00%)	0.00%	0.00%	\$0.00 (0.00%)
468.	/SuperFlexi/Edit.aspx?pageid=965&mid=1601&itemid=1276		10 (0.01%)	8 (0.01%)	00:01:01	0 (0.00%)	0.00%	10.00%	\$0.00 (0.00%)
469.	/village-board-meetings-and-agendas?Edit=Y&ID=247		13 (0.01%)	8 (0.01%)	00:02:26	0 (0.00%)	0.00%	0.00%	\$0.00 (0.00%)
470.	/village-board-meetings-and-agendas?Edit=Y&ID=249		14 (0.01%)	8 (0.01%)	00:02:24	0 (0.00%)	0.00%	7.14%	\$0.00 (0.00%)
471.	/village-board-meetings-and-agendas?STATUS=SD		9 (0.01%)	8 (0.01%)	00:00:07	5 (0.01%)	60.00%	66.67%	\$0.00 (0.00%)
472.	/village-board-meetings-and-agendas?STATUS=SE&ID=217		39 (0.03%)	8 (0.01%)	00:00:06	2 (0.00%)	0.00%	2.56%	\$0.00 (0.00%)
473.	/village-board-meetings-and-agendas?STATUS=SE&ID=230		13 (0.01%)	8 (0.01%)	00:00:03	0 (0.00%)	0.00%	15.38%	\$0.00 (0.00%)
474.	/village-board-meetings-and-agendas?STATUS=SE&ID=235		10 (0.01%)	8 (0.01%)	00:02:07	4 (0.01%)	25.00%	10.00%	\$0.00 (0.00%)
475.	/village-board-meetings-and-agendas?STATUS=SE&ID=243		11 (0.01%)	8 (0.01%)	00:00:49	1 (0.00%)	100.00%	27.27%	\$0.00 (0.00%)
476.	/village-board-meetings-and-agendas?Type=D&ID=240		11 (0.01%)	8 (0.01%)	00:01:23	0 (0.00%)	0.00%	18.18%	\$0.00 (0.00%)
477.	/village-board-meetings-and-agendas?Type=M&ID=170		9 (0.01%)	8 (0.01%)	00:00:58	1 (0.00%)	100.00%	11.11%	\$0.00 (0.00%)
478.	/village-board?embedded_webview=true		10 (0.01%)	8 (0.01%)	00:01:26	8 (0.01%)	62.50%	70.00%	\$0.00 (0.00%)
479.	/zoning-board-of-appeals-meetings-and-agendas?Type=A&ID=174		10 (0.01%)	8 (0.01%)	00:01:32	0 (0.00%)	0.00%	0.00%	\$0.00 (0.00%)
480.	/zoning-board-of-appeals-meetings-and-agendas?Type=M&ID=174		8 (0.01%)	8 (0.01%)	00:07:19	2 (0.00%)	100.00%	37.50%	\$0.00 (0.00%)
481.	/3rd-round-leaf-collection-leaves-out-by-7-am-november-21st-2022-11-21		7 (0.01%)	7 (0.01%)	00:00:17	0 (0.00%)	0.00%	28.57%	\$0.00 (0.00%)
482.	/7-pm-village-board-meeting--2022-04-19		9 (0.01%)	7 (0.01%)	00:00:33	0 (0.00%)	0.00%	11.11%	\$0.00 (0.00%)
483.	/7-pm-village-board-meeting--2022-12-07		7 (0.01%)	7 (0.01%)	00:00:12	0 (0.00%)	0.00%	0.00%	\$0.00 (0.00%)
484.	/admin-email-newsletter		14 (0.01%)	7 (0.01%)	00:08:12	0 (0.00%)	0.00%	28.57%	\$0.00 (0.00%)
485.	/Admin/PageLayout.aspx?pageid=940		19 (0.01%)	7 (0.01%)	00:00:57	0 (0.00%)	0.00%	0.00%	\$0.00 (0.00%)
486.	/christmas-tree-pick-up-trees-must-be-at-the-curb-by-7-am-on-tuesday-january-4th-2022-01-04		8 (0.01%)	7 (0.01%)	00:00:38	1 (0.00%)	0.00%	50.00%	\$0.00 (0.00%)
487.	/Events/ListView.aspx?pageid=957&mid=1586&pagenumber=2		8 (0.01%)	7 (0.01%)	00:00:44	0 (0.00%)	0.00%	12.50%	\$0.00 (0.00%)
488.	/Events/MonthView.aspx?pageid=957&mid=1586&visdate1586=2023-08-01T00:00:00		36 (0.03%)	7 (0.01%)	00:00:03	0 (0.00%)	0.00%	0.00%	\$0.00 (0.00%)
489.	/Events/MonthView.aspx?pageid=957&mid=1586&visdate1586=2023-09-01T00:00:00		35 (0.03%)	7 (0.01%)	00:00:08	0 (0.00%)	0.00%	0.00%	\$0.00 (0.00%)
490.	/HtmlEdit.aspx?mid=1621&pageid=981		12 (0.01%)	7 (0.01%)	00:03:28	0 (0.00%)	0.00%	0.00%	\$0.00 (0.00%)
491.	/HtmlEdit.aspx?mid=1677&pageid=1007		7 (0.01%)	7 (0.01%)	00:00:50	0 (0.00%)	0.00%	0.00%	\$0.00 (0.00%)
492.	/in-person-absentee-voting-800-am-to-430-pm-2022-07-26		8 (0.01%)	7 (0.01%)	00:00:17	2 (0.00%)	50.00%	50.00%	\$0.00 (0.00%)
493.	/in-person-absentee-voting-800-am-to-430-pm-2022-07-27		8 (0.01%)	7 (0.01%)	00:00:27	5 (0.01%)	60.00%	75.00%	\$0.00 (0.00%)
			10	7		0			\$0.00

			10 (0.01%)	7 (0.01%)	00:00:50	3 (0.01%)	100.00%	40.00%	\$0.00 (0.00%)
495.	/lakepatrol.htm		9 (0.01%)	7 (0.01%)	00:00:27	7 (0.01%)	71.43%	77.78%	\$0.00 (0.00%)
496.	/municipal-court/		12 (0.01%)	7 (0.01%)	00:00:54	6 (0.01%)	16.67%	16.67%	\$0.00 (0.00%)
497.	/plan-commission-meetings-and-agendas?STATUS=SE&ID=220		11 (0.01%)	7 (0.01%)	00:01:44	2 (0.00%)	0.00%	0.00%	\$0.00 (0.00%)
498.	/plan-commission-meetings-and-agendas?Type=A&ID=187		13 (0.01%)	7 (0.01%)	00:00:38	1 (0.00%)	0.00%	0.00%	\$0.00 (0.00%)
499.	/plan-commission-meetings-and-agendas?Type=M&ID=203		9 (0.01%)	7 (0.01%)	00:01:37	1 (0.00%)	100.00%	11.11%	\$0.00 (0.00%)
500.	/plan-commission-meetings-and-agendas?Type=M&ID=210		8 (0.01%)	7 (0.01%)	00:03:02	1 (0.00%)	100.00%	12.50%	\$0.00 (0.00%)

Rows 1 - 500 of 4433



To: Jeff Knutson, President
Village Board

From: Scott A. Gosse
Village Administrator

Date: April 13, 2023

Re: Agenda Item 8c, Discussion and Update on Quiet Zone Process

BACKGROUND

This matter is on the agenda at the request of Village President Knutson. Attached for your review, information and background on the Quiet Zone process is a copy of “Guide to the Quiet Zone Establishment Process” published by the Federal Railroad Administration. Earlier this year President Knutson reached out to the Office of the Commission of Railroads regarding whether it would be possible to pursue quiet zones at the Kopmeier Drive and Forest Grove Drive crossings understanding the work is needed to finalize the Oakton Avenue sealed corridor work. The OCR forwarded the request to the FRA as the OCR advised that it does not have jurisdiction over Quiet Zones. Below is an excerpt from the FRA response on the Village President’s inquiry.

ACTION REQUESTED

The action requested of the Village Board is to review the information to be discussed by the Village President on this matter and to provide direction on how to proceed.

ANALYSIS

The following is an excerpt from an email President Knutson received from Mr. Tom Domres, Railroad Crossing Inspector, Federal Railroad Administration:

“As to the question about establishing new Quiet Zones on the ends of the corridor, the answer to this question is: it depends. Here is what I mean:

You cannot skip crossings when you create a Quiet Zone. 49 CFR 222 requires that “a quiet zone may only contain consecutive public highway rail crossings located on a segment of a rail line.” Therefore, Forest Grove Drive and Kopmeier Drive cannot be in the same Quiet Zone until the projects at Wisconsin Avenue and Oakton Avenue are complete. Forest Grove Drive would need to be a stand-alone Quiet Zone, and Kopmeier Drive would need to be a separate stand-alone Quiet Zone.

Would these two crossings qualify as a stand-alone New Quiet Zone? It appears that the Village could move forward with a New Quiet Zone at these locations based on the following:

- The crossings are spaced far enough apart to meet the ½ mile requirements of 49 CRR 222.
- The crossings are being upgraded (or have been upgraded) with Constant Warning Time (CWT) that is required in 49 CFR 222.
- 4 Quadrant Gates are a Supplemental Safety Measure
- Flashing Lights and Gates with Medians are a Supplemental Safety Measure

The Village should consider how to tie the full Quiet Zone together once the Wisconsin Avenue and Oakton Avenue projects are complete. For this to comply with the Regulation, the Village would need to establish a New Quiet at all four crossings. Once in place, the Village would then terminate the single crossing stand-alone Quiet Zones at Forest Grove Drive and Kopmeier Drive. Documents would need to be very clear as to what is the Active Quiet Zone and what is the Terminated Quiet Zone. You don't want to terminate the 4 Crossing Quiet Zone by mistake!

Long story short: it is a little complicated and takes some paperwork. This is not something we see communities doing as most wait until all crossings are ready to establish a New Quiet Zone, but it can be done.”

Attachment



GUIDE TO THE QUIET ZONE ESTABLISHMENT PROCESS

AN INFORMATION GUIDE

Federal Railroad Administration

1200 New Jersey Avenue S.E.
Washington, DC 20590
Telephone: 202-493-6299

www.fra.dot.gov

Federal Railroad Administration

Highway-Rail Crossing and Trespasser Programs Division

Follow FRA on [Facebook](#) and [Twitter](#)

Purpose of the Guide

This brochure was developed to serve as a guide for local decision makers seeking a greater understanding of train horn sounding requirements and how to establish quiet zones. Its purpose is to provide a general overview and thus does not contain every detail about the quiet zone establishment process. For more detailed and authoritative information, the reader is encouraged to review the official regulations governing the use of locomotive horns at public highway-rail grade crossings and the establishment of quiet zones that are contained in 49 CFR Part 222. A copy of the rule can be downloaded or printed at <http://www.fra.dot.gov/eLib/Details/L02809>.

About Quiet Zones



FRA is committed to reducing the number of collisions at highway-rail grade crossings, while establishing a consistent standard for communities who opt to preserve or enhance quality of life for their residents by establishing quiet zones within which routine use of train horns at crossings is prohibited.

Federal regulation requires that locomotive horns begin sounding 15–20 seconds before entering public highway-rail grade crossings, no more than one-quarter mile in advance. Only a public authority, the governmental entity responsible for traffic control or law enforcement at the crossings, is permitted to create quiet zones.

A quiet zone is a section of a rail line at least one-half mile in length that contains one or more consecutive public highway-rail grade crossings at which locomotive horns are not routinely sounded when trains are approaching the crossings. The prohibited use of train horns at quiet zones only applies to trains when approaching and entering crossings and does not include train horn use within passenger stations or rail yards. Train horns may be sounded in emergency situations or to comply with other railroad or FRA rules even within a quiet zone. Quiet zone regulations also do not eliminate the use of locomotive bells at crossings. Therefore, a more appropriate description of a designated quiet zone would be a “reduced train horn area.”

Communities wishing to establish quiet zones must work through the appropriate public authority that is responsible for traffic control or law enforcement at the crossings.

Historical Context

Historically, railroads have sounded locomotive horns or whistles in advance of grade crossings and under other circumstances as a universal safety precaution. Some States allowed local communities to create whistle bans where the train horn was not routinely sounded. In other States, communities created whistle bans through informal agreements with railroads.

In the late 1980's, FRA observed a significant increase in nighttime train-vehicle collisions at certain gated highway-rail grade crossings on the Florida East Coast Railway (FEC) at which nighttime whistle bans had been established in accordance with State statute. In 1991, FRA issued Emergency Order #15 requiring trains on the FEC to sound their horns again. The number and rate of collisions at affected crossings returned to pre-whistle ban levels.



In 1994, Congress enacted a law that required FRA to issue a Federal regulation requiring the sounding of locomotive horns at public highway-rail grade crossings. It also gave FRA the ability to provide for exceptions to that requirement by allowing communities under some circumstances to establish "quiet zones."

The Train Horn Rule became effective on June 24, 2005. The rule set nationwide standards for the sounding of train horns at public highway-rail grade crossings. This rule changed the criteria for sounding the horn from distance-based to time-based. It also set limits on the volume of a train horn. The rule also established a process for communities to obtain relief from the routine sounding of train horns by providing criteria for the establishment of quiet zones. Locomotive horns may still be used in the case of an emergency and to comply with Federal regulations or certain railroad rules.

Because the absence of routine horn sounding increases the risk of a crossing collision, a public authority that desires to establish a quiet zone usually will be required to mitigate this additional risk. At a minimum, each public highway–rail crossing within a quiet zone must be equipped with active warning devices: flashing lights, gates, constant warning time devices (except in rare circumstances) and power out indicators.

In order to create a quiet zone, one of the following conditions must be met

1. ***The Quiet Zone Risk Index (QZRI) is less than or equal to the Nationwide Significant Risk Threshold (NSRT)*** with or without additional safety measures such as Supplementary Safety Measures (SSMs) or Alternative Safety Measures (ASMs) described below. The QZRI is the average risk for all public highway-rail crossings in the quiet zone, including the additional risk for absence of train horns and any reduction in risk due to the risk mitigation measures. The NSRT is the level of risk calculated annually by averaging the risk at all of the Nation’s public highway-rail grade crossings equipped with flashing lights and gates where train horns are routinely sounded.
2. ***The Quiet Zone Risk Index (QZRI) is less than or equal to the Risk Index With Horns (RIWH)*** with additional safety measures such as SSMs or ASMs. The RIWH is the average risk for all public highway-rail crossings in the proposed quiet zone when locomotive horns are routinely sounded.
3. ***Install SSMs at every public highway-rail crossing.*** This is the best method to reduce to reduce risks in a proposed quiet zone and to enhance safety.





SSMs are pre-approved risk reduction engineering treatments installed at certain public highway-rail crossings within the quiet zone and can help maximize safety benefits and minimize risk. SSMs include: medians or channelization devices, one-way streets with gates, four quadrant gate systems, and temporary or permanent crossing closures. Examples of SSMs are shown on the next page.

ASMs are safety systems, other than SSMs, that are used to reduce risk in a quiet zone. ASMs typically are improvements that do not fully meet the requirements to be SSMs and their risk reduction effectiveness must be submitted in writing and approved by FRA.

FRA strongly recommends that all crossings in the quiet zone be reviewed by a diagnostic team. A diagnostic team typically consists of representatives from the public authority, railroad, and State agency responsible for crossing safety and FRA grade crossing managers.

Public Safety Considerations continued

Examples of SSMs

	
<p>Crossing Closure</p>	<p>Four Quadrant Gate System</p>
	
<p>Gates with Channelization Devices</p>	<p>Gates with Medians</p>



Wayside Horns The train horn rule also provides another method for reducing the impact of routine locomotive horn sounding when trains approach public highway-rail grade crossings. A wayside horn may be installed at highway-rail grade crossings that have flashing lights, gates, constant warning time devices (except in rare circumstances), and power out indicators. The wayside horn is positioned at the crossing and will sound when the warning devices are activated. The sound is directed down the roadway, which greatly reduces the noise footprint of the audible warning. Use of wayside horns is not the same as establishing a quiet zone although they may be used within quiet zones.

Cost Considerations

The enabling Federal statute did not provide funding for the establishment of quiet zones. Public authorities seeking to establish quiet zones should be prepared to finance the installation of SSMs and ASMs used. Costs can vary from \$30,000 per crossing to more than \$1 million depending on the number of crossings and the types of safety improvements required.

Legal Considerations

The courts will ultimately determine who will be held liable if a collision occurs at a grade crossing located within a quiet zone, based upon the facts of each case, as a collision may have been caused by factors other than the absence of an audible warning. FRA’s rule is intended to remove failure to sound the horn as a cause of action in lawsuits involving collisions that have occurred at grade crossings within duly established quiet zones.

The Quiet Zone Establishment Process

Under the Train Horn Rule, only public authorities are permitted to establish quiet zones. Citizens who wish to have a quiet zone in their neighborhood should contact their local government to pursue the establishment of a quiet zone. The following is a typical example of the steps taken to establish a quiet zone:

1. **Determine** which crossings will be included in the quiet zone. All public highway-rail crossings in the quiet zone must have, at a minimum, an automatic warning system consisting of flashing lights and gates. The warning systems must be equipped with constant warning time devices (except in rare circumstances) and power out indicators. The length of the quiet zone must be at least one-half mile in length.
2. **Identify** any private highway-rail grade crossings within the proposed quiet zone. If they allow access to the public or provide access to active industrial or commercial sites, a diagnostic review must be conducted and the crossing(s) treated in accordance with the recommendations of the diagnostic team.
3. **Identify** any pedestrian crossings within the proposed quiet zone and conduct a diagnostic review of those crossings too. They also must be treated in accordance with the diagnostic team's recommendations. *NOTE:* While it is not required by the regulations, FRA recommends that every crossing within a proposed quiet zone be reviewed for safety concerns.
4. **Update** the U.S. DOT Crossing Inventory Form to reflect current physical and operating conditions at each public, private, and pedestrian crossing located within a proposed quiet zone.
5. **Provide** a Notice of Intent (NOI) to all of the railroads that operate over crossings in the proposed quiet zone, the State agency responsible for highway safety and the State agency responsible for crossing safety. The NOI must list all of the crossings in the proposed quiet zone and give a brief explanation of the tentative plans for implementing improvements within the quiet zone. Additional required elements of the NOI can be found in 49 CFR 222.43(b). The railroads and State agencies have 60 days in which to provide comments to the public authority on the proposed plan.
6. **Alternative Safety Measures** – If ASMs are going to be used to reduce risk, an application to FRA must be made. The application must include all of the elements provided in 49 CFR 222.39(b)(1) and copies of the application must be sent to the entities listed in 49 CFR 222.39(b)(3). They will have 60 days to provide comments to FRA on the application. FRA will provide a written decision on the application typically within three to four months after it is received.

The Quiet Zone Establishment Process continued

7. **Determine** how the quiet zone will be established using one of the following criteria: (Note that Options 2 through 4 will require the use of the FRA Quiet Zone Calculator available at <http://safetydata.fra.dot.gov/quiet/>.)

1. Every public highway-rail crossing in the proposed quiet zone is equipped with one or more SSMs.
2. The Quiet Zone Risk Index (QZRI) of the proposed quiet zone is less than or equal to the Nationwide Significant Risk Threshold (NSRT) without installing SSMs or ASMs.
3. The QZRI of the proposed quiet zone is less than or equal to the Nationwide Significant Risk Threshold (NSRT) after the installation of SSMs or ASMs.
4. The QZRI of the proposed quiet zone is less than or equal to the Risk Index with Horns (RIWH) after the installation of SSMs or ASMs.



8. **Complete** the installation of SSMs and ASMs and any other required improvements determined by the diagnostic team at all public, private, and pedestrian crossings within the proposed quiet zone.

9. **Ensure** that the required signage at each public, private, and pedestrian crossing is installed in accordance with 49 CFR Sections 222.25, 222.27, and 222.35, and the standards outlined in the Manual on Uniform Traffic Control Devices. These signs may need to be covered until the quiet zone is in effect.

10. **Establish** the quiet zone by providing a Notice of Quiet Zone Establishment to all of the parties that are listed in 49 CFR Section 222.43(a)(3). Be sure to include all of the required contents in the notice as listed in 49 CFR Section 222.43(d). The quiet zone can take effect no earlier than 21 days after the date on which the Notice of Quiet Zone Establishment is mailed.

*****Appendix C to the Train Horn Rule provides detailed, step by step guidance on how to create a quiet zone.*****

Required Documentation

Public authorities interested in establishing a quiet zone are required to submit certain documentation during the establishment process. FRA has provided checklists for the various documents that can be found at <http://www.fra.dot.gov/Elib/Details/L03055>.

FRA's Regional Grade Crossing Managers are available to provide technical assistance. A State's department of transportation or rail regulatory agency also may be able to provide assistance to communities pursuing quiet zones.

Public authorities are encouraged to consult with the agencies in their State that have responsibility for crossing safety. Some States may have additional administrative or legal requirements that must be met in order to modify a public highway-rail grade crossing.

Role of Railroads

Communities seeking to establish a quiet zone are required to send a Notice of Intent and a Notice of Quiet Zone Establishment to railroads operating over the public highway-rail grade crossings within the proposed quiet zone. Railroad officials can provide valuable input during the quiet zone establishment process and should be included on all diagnostic teams. Listed below are links to the Class I Railroads and Amtrak.

BNSF Railway (BNSF)	Canadian Pacific (CP)
CSX Transportation (CSX)	Norfolk Southern (NS)
Canadian National (CN)	Union Pacific (UP)
Kansas City Southern (KCS)	Amtrak (ATK)

FINAL NOTE

The information contained in this brochure is provided as general guidance related to the Quiet Zone Establishment Process and should not be considered as a definitive resource. FRA strongly recommends that any public authority desiring to establish quiet zones take the opportunity to review all aspects of safety along its rail corridor. Particular attention should be given to measures that prevent trespassing on railroad tracks since investments made to establish a quiet zone may be negated if the horn has to be routinely sounded to warn trespassers.

POINTS OF CONTACT

General Questions:

Inga Toye, 202-493-6305

Debra Chappell, 202-493-6018

Ron Ries, 202-493-6285

Regional Contacts

Region 1 Connecticut, Maine, Massachusetts, New Hampshire, New Jersey,
New York, Rhode Island, and Vermont

1-800-724-5991

Region 2 Delaware, Maryland, Ohio, Pennsylvania, Virginia, West Virginia ,
and Washington, D.C.

1-800-724-5992

Region 3 Alabama, Florida, Georgia, Kentucky, Mississippi, North Carolina,
South Carolina, and Tennessee

1-800-724-5993

Region 4 Illinois, Indiana, Michigan, Minnesota, and Wisconsin

1-800-724-5040

Region 5 Arkansas, Louisiana, New Mexico, Oklahoma, and Texas

1-800-724-5995

Region 6 Colorado, Iowa, Kansas, Missouri, and Nebraska

1-800-724-5996

Region 7 Arizona, California, Nevada, and Utah

1-800-724-5997

Region 8 Alaska, Idaho, Montana, North Dakota, South Dakota, Oregon,
Washington, and Wyoming

1-800-724-5998



Rail – Moving America Forward

The mission of the Federal Railroad Administration is to enable the safe, reliable, and efficient movement of people and goods for a strong America, now and in the future.

U.S. Department of Transportation Federal Railroad Administration

1200 New Jersey Avenue S.E.

Washington, DC 20590

Telephone: 202-493-6299

www.fra.dot.gov

Follow FRA on [Facebook](#) and [Twitter](#)

September 2013



To: Jeff Knutson, President
Village Board

From: Scott A. Gosse
Village Administrator

Date: April 13, 2023

Re: Agenda Item 8d, Discussion and Direction on Oakton Avenue Sealed Corridor Project

BACKGROUND

As the Village Board may be aware, one of the outstanding items as it relates to finalizing the sealed corridor project for the Oakton Avenue crossing proposing a permanent solution for the “no left turn” requirement put forth by the Office of the Commissioner of Railroads (OCR) for this crossing. Staff from the Wisconsin Department of Transportation have proposed a solution for Village consideration and staff is bringing this concept forward for Village Board consideration and direction.

ACTION REQUESTED

The action requested of the Village Board is to review and provide direction on how it desires to proceed on this matter.

ANALYSIS

The Village Board is aware of the current delineation to deter left turns onto Clark Street and Capitol Drive. WisDOT staff is proposed consideration of a solution called Kwik Curb (copy of informational brochure attached) as a permanent delineating solution and is seeking input from the Village if this would be acceptable to proceed with proposing to the OCR. WisDOT advises that they would need to the Village to consent to administering the construction of this system as well as the Village agreeing to be responsible for the maintenance of the system long-term. It is my understanding that WisDOT would enter into an agreement with the Village to reimburse the Village for the cost and installation of the system through the WisDOT Railway-Highway Crossing Safety Program.

If the Village Board were amenable to the aforementioned items, WisDOT would seek OCR’s determination that the system would fit their requirements for a permanent installation.

Attachment



**GRADE CROSSING
CONTINUOUS CURBING
AND CHANNELIZING SYSTEM**

QWICK KURB[®]
CHANNELIZING SYSTEMS

Choose from multiple marker configurations.

All QWICK KURB Panels and Bollards are suitable for grade crossing applications.

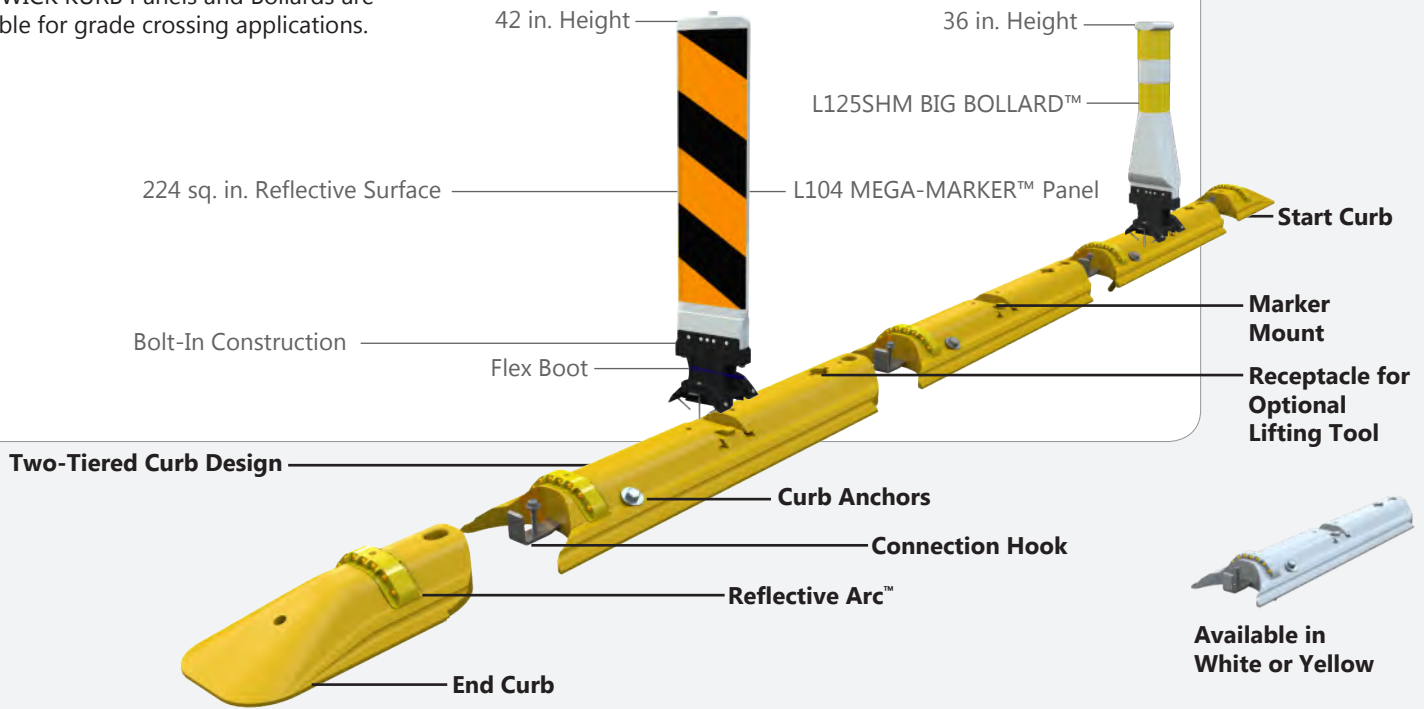

When the QWICK KURB System is installed between yellow lines in a median at a grade crossing intersection, motorists are discouraged from driving around an active railroad gate.

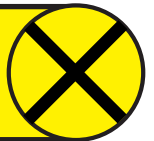

USED EXTENSIVELY IN THE HARSHTEST ENVIRONMENTS

QWICK KURB® MEGA MARKER™ Panels and Continuous Curbing have been tested for over 20 years in all weather conditions. Panels can accept up to 224 square inches of reflective sheeting per side to achieve the highest level of night visibility. In addition, the unique two-part vertical, with rebounding boot support, allows markers to remain upright in the most demanding environments.

QUALIFIES AS AN FRA SUPPLEMENTAL SAFETY MEASURE

The FRA's regulation allows communities to implement safety measures in order to create quiet zones. A community may qualify for a quiet zone by closing crossings or protecting grade crossings with gates, flashing lights, and additional signage; plus one supplemental safety measure (SSM).

SSM categories include temporary closure of the crossing, four quadrant gates, converting streets to one-way, or use of medians with channelization devices.

Medians with channelization devices include markers with high intensity yellow sheeting mounted to raised curbs with reflective arcs. The QWICK KURB System is included and recognized under this category.

While SSMs are generally expensive and maintenance intensive, The QWICK KURB System is the exception.



Two 100 ft. sections of QWICK KURB Continuous Curb, can be installed in about three hours at a fraction of the cost of other SSMs, with little maintenance thereafter. Additional road work or crossing closures are not required to install the system.

Crossings using the QWICK KURB System have proven effective in communities throughout the U.S. and Canada. Several installations are now over ten years old. No other mountable median has proven such durability and effectiveness at discouraging drive-around gate violations.

THE CHANNELIZER DESIGNED FOR ALL WEATHER PERFORMANCE

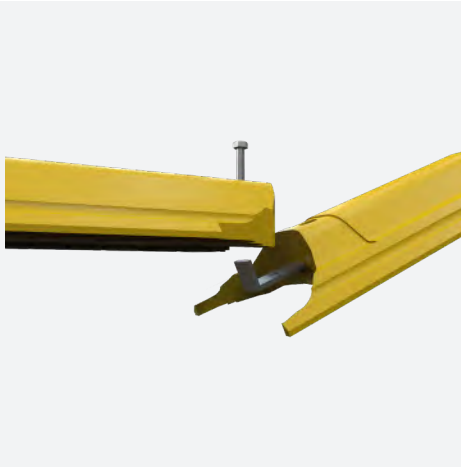

Interlocking Continuous Curb

Just like anchoring barrier wall, a secure connection between curbs is essential. Molding a heavy duty hook into the Continuous Longitudinal Channelizer strengthens the connection.



The Strongest Bond

The combination of a smart two-tier design that can exert downward pressure during a run over, a lateral connection similar to portable concrete barrier and anchors secure the QWICK KURB System to the roadway.



3.5 Inches High, No Vaulting

The unique two tier design of the QWICK KURB System allows the channelizing curb to be as tall as possible without vehicle vaulting.

Molded rubber feet on the bottom of the curb raise the system above the road surface to facilitate water run-off.

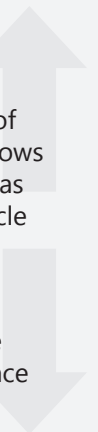

Reboundable Boot

QWICK KURB Panels connect to the curb base using the unique QWICK KURB two-part vertical rebounding flex boot support. This allows for installation of extra-tall 42 inch markers that can spring back to an upright position after an impact.

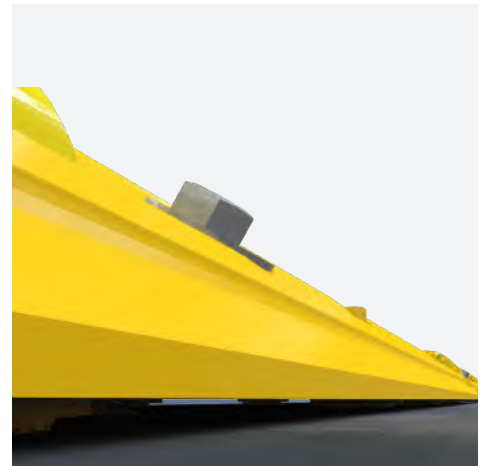
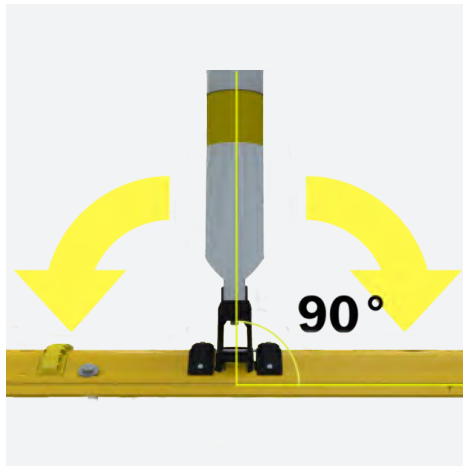
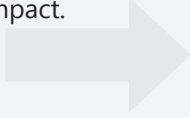

Grade crossing safety upgrades where the QWICK KURB System is installed have proven to reduce gate running by as much as 79%.

A mountable median with channelization is the most cost-effective Federal Railroad Administration Supplementary Safety Measure >>> The QWICK KURB System is the most durable mountable median channelizer available.



QWICK KURB®

CHANNELIZING SYSTEMS

The QWICK KURB® Continuous Curbing System is ideal for harsh environments such as grade crossing intersections where high ADT counts are likely. Formidable uprights on top of a raised continuous curb clearly define the intended travel path and increase motorist compliance while providing superior channelization in all weather conditions, even snow. The QWICK KURB Continuous Curb System meets the eligibility requirements based on MASH or NCHRP 350 criteria as a TL-3 Longitudinal Channelizer. The system can be installed fully anchored, semi-anchored or, in some applications, anchor-free.



QWICK KURB®, INC.

1916 US 41 South • Ruskin, FL 33570 • (813) 645-5072

www.qwickkurb.com

General details for QWICK KURB Systems are subject to change without notice to reflect improvements and upgrades. Always refer to the installation manual for details and cautions.

Additional information is available from QWICK KURB®, INC.

© QWICK KURB®, INC.



**BIKE LANE
CONTINUOUS CURBING
AND CHANNELIZING SYSTEM**

OWICK KURB[®]
CHANNELIZING SYSTEMS

Choose from multiple marker configurations.

All QWICK KURB Panels and Bollards are suitable for bike lane applications.

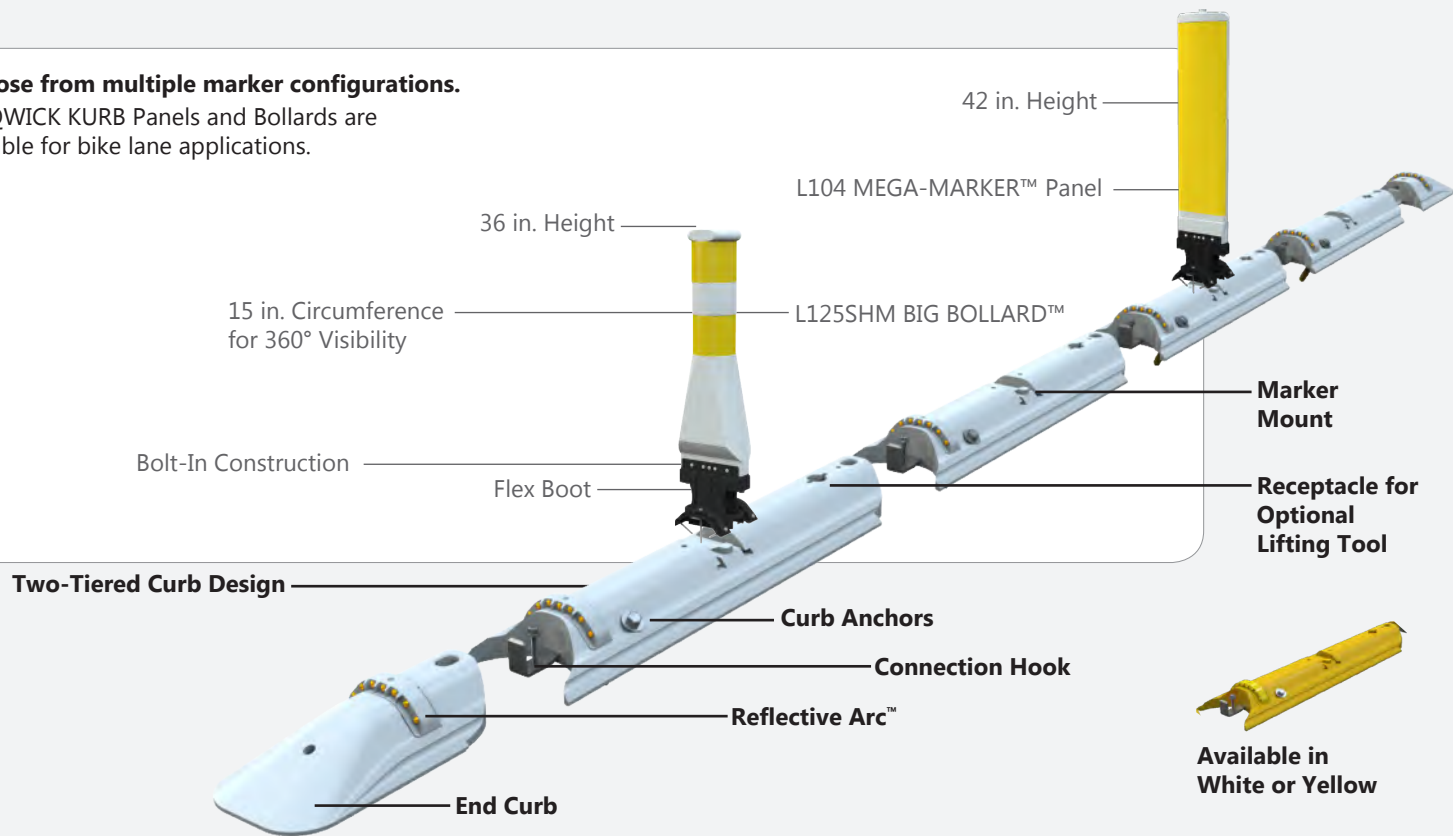

When the QWICK KURB continuous raised curb system is used to mark bike lanes, motorists are more discouraged from driving into restricted bicycle and pedestrian areas.



USED EXTENSIVELY IN THE HARSHTEST ENVIRONMENTS

QWICK KURB® Continuous Curbing with Panels or Bollards has been tested for over 20 years in all weather conditions. Panels can accept 224 square inches of reflective sheeting per side to achieve the highest level of night visibility. In addition, the unique two-part vertical panel with rebounding boot support allows markers to remain upright in the most demanding environments.



SYSTEM CAN WITHSTAND MULTIPLE IMPACTS

Each durable raised curbing element is designed to be anchored to the road surface and interlocked with other elements to create a permanent bond with the roadway. A heavy-duty hook is molded directly into the curb to further strengthen the system.

The two-tier profile is designed to help keep curbing stationary during run overs. In addition, continuous curbing is only 10 5/8" wide making it ideal for urban environments.



MAINTENANCE-FREE CONTEXT SENSITIVE DESIGN

QWICK KURB Continuous Curbing is designed to be installed year round in all climates. The durable design means maintenance is not required for regular use.

The QWICK KURB System optimizes safety for both bike riders and motorists while preserving the aesthetic of the surrounding environment.



To: Jeff Knutson, President
Village Board

From: Scott A. Gosse
Village Administrator

Date: April 14, 2023

Re: Agenda Item _____, Discussion and Possible Action on raSmith Agreement Regarding Kiwanis Village Park Sanitary Sewer Lateral Design and Bid Document

BACKGROUND

This is a project that was reviewed during the 2023 budget discussions and was also presented as a possible use of ARPA funds. Park & Recreation Director Nick Phalin reached out to a local plumbing company for a proposal to install a grinder pump and directional bore a new discharge line from the Village Park pavilion 400 feet to the east to connect to the sanitary sewer main in Caldwell Street. The proposal came in significantly higher than the state bidding threshold amount of \$25,000 which requires the Village to publicly bid this project. The proposed agreement with raSmith would provide for raSmith preparing a design and bid document for the installation of a grinder pump and lateral.

This project is necessary as the current lateral has a minimum pitch from the building to the sanitary sewer main in Caldwell Street which has caused backups in the bathrooms as well as the need for getting the lateral as preventive measures.

ACTION REQUESTED

The action requested of the Village Board is to consider approval of the proposed agreement with raSmith regarding the Kiwanis Village Park sanitary sewer lateral design and bid document.

ANALYSIS

The proposal is on a time and expense basis with an estimated fee of \$6,000. The funding for the engineering agreement as well as the construction related work can come from the Village's Infrastructure Fund which is preliminarily projected to have an estimated balance of \$1,200,000 as of 12/31/2022 (pending final audit).

Attachment



CREATIVITY BEYOND ENGINEERING

R.A. Smith, Inc.
16745 W. Bluemound Road
Brookfield, WI 53005-5938
(262) 781-1000 | rasmith.com

April 14, 2023

Mr. Scott Gosse
Village Administrator
235 Hickory Street
Pewaukee, WI 53072

Re: Proposal for Kiwanis Village Park Sanitary Sewer Lateral Relay

Dear Mr. Gosse:

Thank you for allowing raSmith to provide you with a proposal for professional services. Below is our proposed scope of service, schedule and fees for the project.

Scope of Services

- A. Perform site investigation and elevation survey over the existing/proposed sanitary sewer lateral.
- B. Prepare a plan and profile drawing using aerial photo as a background.
- C. Prepare a project manual to include bidding documents, agreement and specifications.
- D. Bidding services to include providing a bid advertisement to the Village for publishing, posting the documents on Quest CDN, answering questions during bidding, attending the virtual bid opening, providing a bid summary and recommendation and preparing the contract documents for execution.

Completion Schedule

We will work with you to meet the project deadline and to establish an acceptable schedule that will be mutually agreed upon prior to beginning work. We anticipate a two-week time frame to perform the survey and prepare the documents for bidding.

Professional Fees

The above services will be provided for a time and expense fee estimated to be \$6,000. Services will be billed each month based on the work completed.

Usual and customary expenses such as mileage, printing, delivery and postage are not included in the fee and will be billed at cost as a reimbursable expense.

The terms and conditions set forth herein are valid for 150 days from the date of this proposal and are conditioned upon our completion of all services within 60 days thereafter.

If you would like to authorize raSmith to proceed with your project, please provide written authorization to proceed. The agreement terms and Standard Terms and Conditions as part of from our existing professional Engineering Services Agreement shall govern this work. We look forward to working with you on this project.

Sincerely,
raSmith

Timothy G. Barbeau, P.E., P.L.S.
Senior Project Manager



235 Hickory Street - Pewaukee, WI

Committee APPLICATION

If you are interested in serving the community as a committee member, please complete this application form. If applying for an existing vacancy, your committee application will be kept on file until after an appointment has been made. If no vacancy currently exists, your application will be kept on file until a vacancy occurs. If you have any additional questions, please feel free to contact Village Hall by calling (262) 691-5660 or email the Village President at villagepresident@villageofpewaukee.com.

First Name Kristen	M.I. E	Last Name Kreuser	
Applicant's Residence: Street Address 429 Pirate Pass		City Pewaukee	State WI
		Zip 53072	
Home Phone: 262-470-2527	Work Phone:	Cell Phone:	
Home Email: kkreuser28@gmail.com		Work Email:	

Choose a Committee(s)	
<input type="checkbox"/> Board of Review	<input type="checkbox"/> Police Commission
<input type="checkbox"/> Historic Preservation Commission	<input type="checkbox"/> Public Works & Safety Committee
<input type="checkbox"/> Joint Library Board	<input type="checkbox"/> Sex Offender Residency Appeal Board
<input checked="" type="checkbox"/> Joint Parks & Recreation	<input type="checkbox"/> Zoning Board of Appeals
<input type="checkbox"/> Plan Commission	<input type="checkbox"/> Other (please specify): _____

Background (related experience, skills, or qualifications): Pirate Properties (Present - 2022) Best Friends Animal Society (2022-2019), Kohls Corporate (2009 - 2019) Retail Financial Planner who developed and managed strategic and financial plans to drive sales growth and increase profitability Hired and Managed a team & successfully worked with various cross-functional teams. Small business owner / real estate investor.
--

Why are you interested in this committee(s): I am interested in serving our community and the Village of Pewaukee. The Park and Rec Board would be a great fit for me. Having two young kids in the area, we are engrained in the park and rec community and experience. I would like to be a value add to the Board, and my financial background, real estate knowledge, and creative problem solving skills will ensure I can be a benefit to Pewaukee in this role

Kristen Kreuser 4/11/2023
Applicant's Signature & Date

Report Criteria:

Report type: Invoice detail
 Check.Type = {<>} "Adjustment"

GL Period	Check Issue Date	Check Number	Payee	Invoice Number	Description	Check Amount
71177						
03/23	03/09/2023	71177	WISCONSIN LAW ENFOR	29	2023 WILEAG ANNUAL DUES	650.00- V
Total 71177:						650.00-
71519						
03/23	03/03/2023	71519	AMAZON CAPITAL SERVI	13Y1-J3CD-K	LIBRARY/ADULT PROGRAMMING SUPPLIES	24.98
03/23	03/03/2023	71519	AMAZON CAPITAL SERVI	1J16-HW9F-N	LIBRARY/PROCESSING SUPPLIES	26.98
03/23	03/03/2023	71519	AMAZON CAPITAL SERVI	1WTX-1TY9-Q	LIBRARY/7 JUV NF BOOKS	109.70
Total 71519:						161.66
71520						
03/23	03/03/2023	71520	ARAMARK UNIFORM & C	6140122749	SEWER UNIFORMS	171.26
03/23	03/03/2023	71520	ARAMARK UNIFORM & C	6140126632	SEWER UNIFORMS	176.76
03/23	03/03/2023	71520	ARAMARK UNIFORM & C	6140130538	SEWER UNIFORMS	176.76
03/23	03/03/2023	71520	ARAMARK UNIFORM & C	6140133282	MAT EXCHANGE FEB 2023	40.10
03/23	03/03/2023	71520	ARAMARK UNIFORM & C	6140134668	SEWER UNIFORMS	176.76
Total 71520:						741.64
71521						
03/23	03/03/2023	71521	ASSOCIATED APPRAISAL	167169	ASSESSOR/FULL VALUE MAINT-MARCH 2023	3,583.33
Total 71521:						3,583.33
71522						
03/23	03/03/2023	71522	BROOKFIELD BUICK GM	5023912	#128-COUNCIL STROBE SWITCH	65.93
Total 71522:						65.93
71523						
03/23	03/03/2023	71523	CITY OF DELAFIELD	02022023	POLICE/2023 SCIT DUES	7,500.00
Total 71523:						7,500.00
71524						
03/23	03/03/2023	71524	COMET WELDING INC	8064	#127 MOUNT TAILGATE FINS	120.00
Total 71524:						120.00
71525						
03/23	03/03/2023	71525	CORE & MAIN LP	S361135	HYDRANT REPAIR 418 SANDY CIRCLE	361.46
Total 71525:						361.46
71526						
03/23	03/03/2023	71526	DIXON ENGINEERING IN	23-0034	AT&T & SUNNYRIDGE/NEXIUS	1,750.00
Total 71526:						1,750.00

GL Period	Check Issue Date	Check Number	Payee	Invoice Number	Description	Check Amount
71527						
03/23	03/03/2023	71527	E H WOLF & SONS INC	366085	ISO 68 OIL FOR PUMP MOTORS	706.25
Total 71527:						706.25
71528						
03/23	03/03/2023	71528	FERGUSON WATERWOR	380811	2" COMPRESSION UNION AND STAINLESS SLEEVE INSERT FO	316.00
Total 71528:						316.00
71529						
03/23	03/03/2023	71529	HAWKINS INC	6387466	CHLORINE	5,885.98
Total 71529:						5,885.98
71530						
03/23	03/03/2023	71530	J & H HEATING INC	W35949	LIBRARY/HEATING MAINTENANCE	396.91
Total 71530:						396.91
71531						
03/23	03/03/2023	71531	JFTCO INC / FABICK CAT	RIWK0001061	SCISSOR LIFT RENTAL FOR MOVE INTO NEW BUILDING	457.50
Total 71531:						457.50
71532						
03/23	03/03/2023	71532	JR BADGES	20016	POLICE/JR POLICE BADGE STICKERS FOR COMMUNITY	350.00
Total 71532:						350.00
71533						
03/23	03/03/2023	71533	JX ENTERPRISES, INC	12218398P	#127 WHEEL NUT & WHEEL NUT COVER (4)	44.35
Total 71533:						44.35
71534						
03/23	03/03/2023	71534	KAESTNER AUTO ELECT	419498	VANAIR 5000 JUMP PK	659.00
03/23	03/03/2023	71534	KAESTNER AUTO ELECT	419499	VANAIR 10000 AMP JUMP PACK	759.99
Total 71534:						1,418.99
71535						
03/23	03/03/2023	71535	LAKESIDE INTERNATION	5170761P	#127 - AIR BAG KIT	1,280.12
Total 71535:						1,280.12
71536						
03/23	03/03/2023	71536	LANNON STONE PRODU	1359432	STONE (18.92 TON) 1302 SUNNYRIDGE SERVICE LEAK	296.67
03/23	03/03/2023	71536	LANNON STONE PRODU	1359798	#1 STONE (17.04T) WATERMAIN BREAK HIGH ST & CHESHIRE	267.19
Total 71536:						563.86
71537						
03/23	03/03/2023	71537	MADISON NATIONAL LIF	1539994	DISABILITY INSURANCE/FEB 2023	3,580.14
03/23	03/03/2023	71537	MADISON NATIONAL LIF	1546764	DISABILITY INSURANCE/MAR 2023	2,879.13

GL Period	Check Issue Date	Check Number	Payee	Invoice Number	Description	Check Amount
Total 71537:						6,459.27
71538						
03/23	03/03/2023	71538	MIDWEST METER INC	0151765-IN	3" & 6" TURBO HEAD ASSMBLY TEST	840.00
03/23	03/03/2023	71538	MIDWEST METER INC	0151766-IN	AMR III MALE 1.75 FT BLACK (10)	104,298.50
Total 71538:						105,138.50
71539						
03/23	03/03/2023	71539	MOD-U-DOCK	2794	FISHING PIER 50% DEPOSIT	35,545.00
Total 71539:						35,545.00
71540						
03/23	03/03/2023	71540	MORAIN DEVELOPMEN	3019212	IMPORTED FILL 1302 SUNNYRIDGE WATER SERVICE LEAK	67.32
03/23	03/03/2023	71540	MORAIN DEVELOPMEN	3019289	IMPORTED FILL 02.13.23 WATERMAIN BREAK HIGH ST & CHES	67.32
Total 71540:						134.64
71541						
03/23	03/03/2023	71541	MOTION & CONTROL EN	C27936-001	NEW DPW SHOP AIR LINE FITTINGS	226.26
Total 71541:						226.26
71542						
03/23	03/03/2023	71542	PEWAUKEE PARKS & RE	02212023	LIBRARY/MARKETING_SUMMER ACTIVITY GUIDE	825.00
Total 71542:						825.00
71543						
03/23	03/03/2023	71543	REGISTRATION FEE TRU	43397	POLICE/VEH REGISTRATION FOR NEW SQUAD	5.00
Total 71543:						5.00
71544						
03/23	03/03/2023	71544	RHODE, ADAM	0218203	POLICE/REIMBURSEMENT RHODE FOR LARGE SCALES	13.00
Total 71544:						13.00
71545						
03/23	03/03/2023	71545	ROBERT W BAIRD & CO	PF-22001813	2022 REFI FINANCIAL ADVISORY & OFFICIAL STATEMENT FEE	36,800.00
Total 71545:						36,800.00
71546						
03/23	03/03/2023	71546	SHERWIN-WILLIAMS CO	8946-3	2023 TRAFFIC PAINT & GLASS BEADS	6,583.00
Total 71546:						6,583.00
71547						
03/23	03/03/2023	71547	SOERENS FORD INC	47775	#101 2013 FORD EXPLORER SWAY BAR LINKS & HARDWARE	118.47
Total 71547:						118.47

GL Period	Check Issue Date	Check Number	Payee	Invoice Number	Description	Check Amount
71548						
03/23	03/03/2023	71548	STAPLES ADVANTAGE	8069192368	OFFICE CHAIR MAT (2)	76.38
Total 71548:						76.38
71549						
03/23	03/03/2023	71549	STATE OF WISCONSIN C	02282023	STATE SURCHARGES	5,826.48
Total 71549:						5,826.48
71550						
03/23	03/03/2023	71550	US CELLULAR	0559519758	POLICE/CELL PHONE 01/01/2023-02/02/2023	437.31
Total 71550:						437.31
71551						
03/23	03/03/2023	71551	WAUKESHA COUNTY TR	02282023	COUNTY SURCHARGES- FEB	1,315.57
03/23	03/03/2023	71551	WAUKESHA COUNTY TR	20040016	INMATE BILLING- FEB 2023	39.44
Total 71551:						1,355.01
71552						
03/23	03/03/2023	71552	WISCONSIN STATE LABO	727074 - B	SHORT PAID INVOICE 727074	2.00
Total 71552:						2.00
71553						
03/23	03/03/2023	71553	REGISTRATION FEE TRU	54719	POLICE/TRANSFER OF LICENSE PLATE FOR NEW SQUAD	1.00
Total 71553:						1.00
71554						
03/23	03/10/2023	71554	AMAZON CAPITAL SERVI	197R-LX16-PT	LIBRARY/BOARD GAME COLLECTION	10.99
03/23	03/10/2023	71554	AMAZON CAPITAL SERVI	1G7N-VCC4-N	LIBRARY/BOARD GAME COLLECTION	12.93
03/23	03/10/2023	71554	AMAZON CAPITAL SERVI	1HY6-76MX-J	LIBRARY/ADULT PROGRAM SUPPLIES	32.87
03/23	03/10/2023	71554	AMAZON CAPITAL SERVI	1V7D-PVGL-D	LIBRARY/ADULT NON FIC BKS	42.84
Total 71554:						99.63
71555						
03/23	03/10/2023	71555	BAKER & TAYLOR BOOK	2037322549	LIBRARY/FREIGHT CHARGE	106.75
03/23	03/10/2023	71555	BAKER & TAYLOR BOOK	2037333878	LIBRARY/FREIGHT CHARGE	67.64
Total 71555:						174.39
71556						
03/23	03/10/2023	71556	BIG JIM'S SMALL ENGINE	131429	POLE SAW DRIVERS	42.82
Total 71556:						42.82
71557						
03/23	03/10/2023	71557	BLACKSTONE PUBLISHI	2086589	LIBRARY/ADULT 1 AUDIO CDS	34.95
03/23	03/10/2023	71557	BLACKSTONE PUBLISHI	2087454	LIBRARY/ADULT 4 AUDIO CDS	156.01
Total 71557:						190.96

GL Period	Check Issue Date	Check Number	Payee	Invoice Number	Description	Check Amount
71558						
03/23	03/10/2023	71558	BUELOW VETTER BUIKE	3358-80237 -	GENERAL LABOR MATTER	76.50
Total 71558:						76.50
71559						
03/23	03/10/2023	71559	CITY OF BROOKFIELD	20230130	4TH QTR 2022 PROCESS CHARGES-ENG CUSTOM COATINGS	16,583.18
03/23	03/10/2023	71559	CITY OF BROOKFIELD	20230203	4TH QTR OPER CHARGES- CAPITAL	228,604.87
Total 71559:						245,188.05
71560						
03/23	03/10/2023	71560	CITY OF PEWAUKEE	FEB-MAR FIR	FEB/MARCH FIRE/EMS	340,052.84
Total 71560:						340,052.84
71561						
03/23	03/10/2023	71561	COMET WELDING INC	8085	#109 FRONT PLOW-FIX CRACKS ON TRIP EDGE	201.25
Total 71561:						201.25
71562						
03/23	03/10/2023	71562	GIUFFRE BROS. CRANE	105759	STORAGE 02.20 TO 03.19.23	320.00
Total 71562:						320.00
71563						
03/23	03/10/2023	71563	LAKESIDE INTERNATION	1385932P	#127 CAB VENT EXHAUST	20.79
Total 71563:						20.79
71564						
03/23	03/10/2023	71564	LAWSON PRODUCTS, IN	9310364289	MISC METRIC HARDWARE	79.82
03/23	03/10/2023	71564	LAWSON PRODUCTS, IN	9310366396	MISC HARDWARE	11.73
03/23	03/10/2023	71564	LAWSON PRODUCTS, IN	9310370479	CABLE TIES - TOOLS	15.75
Total 71564:						107.30
71565						
03/23	03/10/2023	71565	LUICK, MELISSA	WORK BOOT	M.LUICK 2023 WORK BOOT REIMBURSE	200.00
Total 71565:						200.00
71566						
03/23	03/10/2023	71566	MIDWEST TAPE	503397954	LIBRARY/ADULT 5 DVDS	103.45
03/23	03/10/2023	71566	MIDWEST TAPE	503397955	LIBRARY/ 1 ADULT CD	13.99
03/23	03/10/2023	71566	MIDWEST TAPE	503397956	LIBRARY/1 ADULT DVD	18.74
03/23	03/10/2023	71566	MIDWEST TAPE	503397957	LIBRARY/6 ADULT DVD	110.94
03/23	03/10/2023	71566	MIDWEST TAPE	503397958	LIBRARY/1 ADULT DVD	20.99
03/23	03/10/2023	71566	MIDWEST TAPE	503397959	LIBRARY/ADULT 2 DVDS	22.38
03/23	03/10/2023	71566	MIDWEST TAPE	503398131	LIBRARY/ 1 ADULT CD	13.59
03/23	03/10/2023	71566	MIDWEST TAPE	503398132	LIBRARY/JUVENILE 1 DVD	14.39
03/23	03/10/2023	71566	MIDWEST TAPE	503398133	LIBRARY/JUVENILE 3 DVD	71.22
Total 71566:						389.69

GL Period	Check Issue Date	Check Number	Payee	Invoice Number	Description	Check Amount
71567						
03/23	03/10/2023	71567	NORTHERN LAKE SERVI	2301224	02.08.23 COLIFORM TESTING	100.00
03/23	03/10/2023	71567	NORTHERN LAKE SERVI	2301440	02.15.23 COLIFORM TESTING	100.00
03/23	03/10/2023	71567	NORTHERN LAKE SERVI	2301533	02.18.23 RADIOACTIVITY	1,288.80
03/23	03/10/2023	71567	NORTHERN LAKE SERVI	2301687	02.19.23 RADIOACTIVITY	644.40
03/23	03/10/2023	71567	NORTHERN LAKE SERVI	2301764	02.20.23 RADIOACTIVITY STUDY	1,611.00
03/23	03/10/2023	71567	NORTHERN LAKE SERVI	2301955	02.22.23 RADIOACTIVITY STUDY	1,611.00
03/23	03/10/2023	71567	NORTHERN LAKE SERVI	2301987	02.23.23 COLIFORM TESTING	100.00
Total 71567:						5,455.20
71568						
03/23	03/10/2023	71568	PFEIL, DANIEL	02022023	POLICE/PFEIL REIMBURSEMENT VEST CARRIER AND SUPPLIE	281.56
Total 71568:						281.56
71569						
03/23	03/10/2023	71569	RECYCLE TECHNOLOGI	233249	DPW REFRIGERATOR RECYCLING (2)	40.00
Total 71569:						40.00
71570						
03/23	03/10/2023	71570	TDS	MARCH 2023	TELEPHONE	2,397.11
Total 71570:						2,397.11
71571						
03/23	03/10/2023	71571	WALMART	23000250	RESTITUION	53.90
03/23	03/10/2023	71571	WALMART	23000773	RESTITUION	164.76
Total 71571:						218.66
71572						
03/23	03/10/2023	71572	WE ENERGIES	4490648670	515 KOPMEIER DR - KOPMEIER LIFT	6,327.28
Total 71572:						6,327.28
71573						
03/23	03/17/2023	71573	AMAZON CAPITAL SERVI	1LCC-TT6R-V	LIBRARY/JUV PROGRAM SUPPLIES	27.99
03/23	03/17/2023	71573	AMAZON CAPITAL SERVI	1PJX-KYYT-T	LIBRARY/OFFICE SUPPLIES	44.43
03/23	03/17/2023	71573	AMAZON CAPITAL SERVI	1TFP-7DLG-T	LIBRARY/1 ADULT FIC BK	37.97
03/23	03/17/2023	71573	AMAZON CAPITAL SERVI	1VG4-XVN4-T	LIBRARY/JUV PROGRAM SUPPLIES	58.42
03/23	03/17/2023	71573	AMAZON CAPITAL SERVI	1WQX-TRYP-	LIBRARY/DISPLAYS	30.69
Total 71573:						199.50
71574						
03/23	03/17/2023	71574	BADGER METER INC	80121713	BEACON HOSTING FEE- FEBRUARY 2444/504 LTE	546.32
Total 71574:						546.32
71575						
03/23	03/17/2023	71575	BAKER & TAYLOR BOOK	2037254928	LIBRARY/PROCESSING	44.49
03/23	03/17/2023	71575	BAKER & TAYLOR BOOK	2037289085	LIBRARY/FREIGHT CHARGE	67.71
03/23	03/17/2023	71575	BAKER & TAYLOR BOOK	2037295485	LIBRARY/FREIGHT CHARGE	10.60
03/23	03/17/2023	71575	BAKER & TAYLOR BOOK	2037301096	LIBRARY/PROCESSING	380.50

GL Period	Check Issue Date	Check Number	Payee	Invoice Number	Description	Check Amount
03/23	03/17/2023	71575	BAKER & TAYLOR BOOK	2037301113	LIBRARY/FREIGHT CHARGE	187.14
03/23	03/17/2023	71575	BAKER & TAYLOR BOOK	2037301564	LIBRARY/FREIGHT CHARGE	24.00
03/23	03/17/2023	71575	BAKER & TAYLOR BOOK	2037304526	LIBRARY/GIFT ACCT/TRIXIE LAWRENCE MEMORIAL	14.14
03/23	03/17/2023	71575	BAKER & TAYLOR BOOK	2037305851	LIBRARY/FREIGHT CHARGE	464.47
03/23	03/17/2023	71575	BAKER & TAYLOR BOOK	2037310161	LIBRARY/FREIGHT CHARGE	43.54
03/23	03/17/2023	71575	BAKER & TAYLOR BOOK	2037310286	LIBRARY/FREIGHT CHARGE	12.72
03/23	03/17/2023	71575	BAKER & TAYLOR BOOK	2037310294	LIBRARY/FREIGHT CHARGE	55.40
03/23	03/17/2023	71575	BAKER & TAYLOR BOOK	2037317891	LIBRARY/FREIGHT CHARGE	11.02
03/23	03/17/2023	71575	BAKER & TAYLOR BOOK	2037318373	LIBRARY/FREIGHT CHARGE	294.53
03/23	03/17/2023	71575	BAKER & TAYLOR BOOK	2037318382	LIBRARY/FREIGHT CHARGE	466.12
03/23	03/17/2023	71575	BAKER & TAYLOR BOOK	2037318421	LIBRARY/PROCESSING	102.22
03/23	03/17/2023	71575	BAKER & TAYLOR BOOK	2037324506	LIBRARY/FREIGHT CHARGE	147.21
03/23	03/17/2023	71575	BAKER & TAYLOR BOOK	2037325908	LIBRARY/FREIGHT CHARGE	532.07
03/23	03/17/2023	71575	BAKER & TAYLOR BOOK	2037334179	LIBRARY/FREIGHT CHARGE	548.84
03/23	03/17/2023	71575	BAKER & TAYLOR BOOK	2037337372	LIBRARY/FREIGHT CHARGE	408.79
03/23	03/17/2023	71575	BAKER & TAYLOR BOOK	2037337641	LIBRARY/FREIGHT CHARGE	104.61
03/23	03/17/2023	71575	BAKER & TAYLOR BOOK	2037341010	LIBRARY/FREIGHT CHARGE	89.16
03/23	03/17/2023	71575	BAKER & TAYLOR BOOK	2037341127	LIBRARY/FREIGHT CHARGE	92.69
03/23	03/17/2023	71575	BAKER & TAYLOR BOOK	2037341391	LIBRARY/FREIGHT CHARGE	11.75
03/23	03/17/2023	71575	BAKER & TAYLOR BOOK	2037348844	LIBRARY/FREIGHT CHARGE	50.26
03/23	03/17/2023	71575	BAKER & TAYLOR BOOK	2037353458	LIBRARY/FREIGHT CHARGE	272.63
03/23	03/17/2023	71575	BAKER & TAYLOR BOOK	2037355449	LIBRARY/FREIGHT CHARGE	186.81
03/23	03/17/2023	71575	BAKER & TAYLOR BOOK	2037355464	LIBRARY/FREIGHT CHARGE	61.20
03/23	03/17/2023	71575	BAKER & TAYLOR BOOK	2037355819	LIBRARY/FREIGHT CHARGE	36.35
03/23	03/17/2023	71575	BAKER & TAYLOR BOOK	2037357384	LIBRARY/FREIGHT CHARGE	298.81
Total 71575:						5,019.78
71576						
03/23	03/17/2023	71576	BLACKSTONE PUBLISHI	2085154	LIBRARY/ADULT 1 AUDIO CD	34.95
Total 71576:						34.95
71577						
03/23	03/17/2023	71577	BURKE TRUCK & EQUIP	31306	MISC PLOW PARTS INCLUDING - CUTTING EDGES, CURB, SHO	2,063.33
Total 71577:						2,063.33
71578						
03/23	03/17/2023	71578	BV TETZLAFF	5846	WATER SVC REPAIR 1302 SUNNYRIDGE	4,505.00
03/23	03/17/2023	71578	BV TETZLAFF	5847	WATER MAIN REPAIR 536 HIGH ST	3,620.00
Total 71578:						8,125.00
71579						
03/23	03/17/2023	71579	CHAVEZ, LISA	02222023	LIBRARY/REIMBURSE PATRON FOR FOUND ITEM	16.00
Total 71579:						16.00
71580						
03/23	03/17/2023	71580	HIPPENMEYER REILLY B	54191 & 5419	GENERAL COURT LEGAL	6,263.00
Total 71580:						6,263.00
71581						
03/23	03/17/2023	71581	HYDROCORP	71171-IN	CROSS CONNECT PRGM FEB 2023	2,137.00

GL Period	Check Issue Date	Check Number	Payee	Invoice Number	Description	Check Amount
Total 71581:						2,137.00
71582						
03/23	03/17/2023	71582	JAMES IMAGING SYSTE	33575939	LIBRARY/MONTHLY COPIER LEASE/MARCH 2023	849.84
Total 71582:						849.84
71583						
03/23	03/17/2023	71583	JF AHERN COMPANY	561334	LIBRARY/FIRE ALARM-FEB ANNUAL 2023	315.00
Total 71583:						315.00
71584						
03/23	03/17/2023	71584	KAESTNER AUTO ELECT	420006	#104 SALTER CONTROL TOGGLE SWITCH & FUSE	12.99
03/23	03/17/2023	71584	KAESTNER AUTO ELECT	420007	#104 MAX 30 FUSE	3.01
Total 71584:						16.00
71585						
03/23	03/17/2023	71585	KEMPEN MASONRY LLC	7512	LIBRARY/SALT-PLOW 2.16.23	720.00
03/23	03/17/2023	71585	KEMPEN MASONRY LLC	7519	LIBRARY/SALT SVC 2.22.23	176.25
03/23	03/17/2023	71585	KEMPEN MASONRY LLC	7531	LIBRARY/SALT-PLOW 2.22.23 AND 2.23.23	1,153.75
03/23	03/17/2023	71585	KEMPEN MASONRY LLC	7540	LIBRARY/SALT-PLOW 2.25.23	511.25
Total 71585:						2,561.25
71586						
03/23	03/17/2023	71586	LAKE COUNTRY AUTOCA	94943	#640 MOUNT AND BALANCE (4) TIRES	95.00
Total 71586:						95.00
71587						
03/23	03/17/2023	71587	MIDWEST TAPE	503320135	LIBRARY/ 1 ADULT CD	13.99
03/23	03/17/2023	71587	MIDWEST TAPE	503320137	LIBRARY/1 ADULT DVD	26.24
03/23	03/17/2023	71587	MIDWEST TAPE	503320138	LIBRARY/ADULT 4 DVDS	86.21
03/23	03/17/2023	71587	MIDWEST TAPE	503320139	LIBRARY/JUVENILE 3 DVD	22.47
03/23	03/17/2023	71587	MIDWEST TAPE	503320270	LIBRARY/JUVENILE 2 DVD	19.98
03/23	03/17/2023	71587	MIDWEST TAPE	503411723	LIBRARY/ADULT 2 DVDS	38.23
03/23	03/17/2023	71587	MIDWEST TAPE	503411724	LIBRARY/1 ADULT DVD	4.49
03/23	03/17/2023	71587	MIDWEST TAPE	503411725	LIBRARY/ 2 ADULT CDS	23.98
03/23	03/17/2023	71587	MIDWEST TAPE	503411727	LIBRARY/ADULT 3 DVDS	77.97
03/23	03/17/2023	71587	MIDWEST TAPE	503411728	LIBRARY/ 1 JUV CD	12.79
Total 71587:						326.35
71588						
03/23	03/17/2023	71588	MIDWEST TAPE - HOOPL	503441134	LIBRARY/DIGITAL ACCT ENDING 2/28/23	477.20
Total 71588:						477.20
71589						
03/23	03/17/2023	71589	MISSION COMMUNICATI	1073605	LK LEVL SVC 03.01.23 TO 02.29.24 - CHARGEBACK 50% TO LPS	347.40
Total 71589:						347.40

GL Period	Check Issue Date	Check Number	Payee	Invoice Number	Description	Check Amount
71590						
03/23	03/17/2023	71590	PEWAUKEE SCHOOL DIS	FEB 2023	MOBILE HOME FEES FEB 2023	93.86
03/23	03/17/2023	71590	PEWAUKEE SCHOOL DIS	JAN 2023	MOBILE HOME FEES JAN 2023	93.86
Total 71590:						187.72
71591						
03/23	03/17/2023	71591	POMP'S TIRE SERVICE I	60299958	#640/4 TIRES	642.48
Total 71591:						642.48
71592						
03/23	03/17/2023	71592	PROVEN POWER, INC	01-421340	#116 - RIGHT REAR SIDE LIGHT	101.58
Total 71592:						101.58
71593						
03/23	03/17/2023	71593	RUEKERT & MIELKE, INC	145548	SCADA OPERATOR 10 INSTALL	2,085.72
03/23	03/17/2023	71593	RUEKERT & MIELKE, INC	145549	KOPMEIER LIFT STATION DESIGN	10,688.50
03/23	03/17/2023	71593	RUEKERT & MIELKE, INC	145550	WELL 4 HMO DESIGN PILOT TEST	475.75
03/23	03/17/2023	71593	RUEKERT & MIELKE, INC	145551	WELL 4 HMO DESIGN	1,259.25
Total 71593:						14,509.22
71594						
03/23	03/17/2023	71594	SHRED-IT USA	8003405498	POLICE/PAPER SHRED 02-22-2023	62.97
Total 71594:						62.97
71595						
03/23	03/17/2023	71595	SOERENS FORD INC	47884	#645-FLEX TUBE ASY	83.34
Total 71595:						83.34
71596						
03/23	03/17/2023	71596	TAYLOR COMPUTER SER	24392	LIBRARY/NEW PC AND INSTALLATION	1,384.65
03/23	03/17/2023	71596	TAYLOR COMPUTER SER	24396	DPW WORKSTATION	1,872.95
Total 71596:						3,257.60
71597						
03/23	03/17/2023	71597	WASTE MANAGEMENT	0460390-4163	SOLID WASTE REFUSE	26,085.37
Total 71597:						26,085.37
71598						
03/23	03/17/2023	71598	WAUKESHA LIME AND ST	1850154	COLD PATCH FOR HIGH ST & CHESHIRE MAIN BREAK	1,371.75
Total 71598:						1,371.75
71599						
03/23	03/17/2023	71599	WISCONSIN STATE LABO	736869	FLOURIDE TEST 02.09.23	28.00
Total 71599:						28.00

GL Period	Check Issue Date	Check Number	Payee	Invoice Number	Description	Check Amount
71600						
03/23	03/24/2023	71600	ALL STAR HEATING & CO	352471	VILLAGE HALL ROOF TOP - DIAGNOSE & REPLACE IGNITOR	219.82
Total 71600:						219.82
71601						
03/23	03/24/2023	71601	CENTER POINT LARGE P	1992646	LIBRARY/2 LARGE PRINT BOOKS	49.14
Total 71601:						49.14
71602						
03/23	03/24/2023	71602	CHARTER COMMUNICATI	007630203182	INTERNET 03.18 TO 04.17.23	169.98
Total 71602:						169.98
71603						
03/23	03/24/2023	71603	CIMPL, GEOFF	03072023	POLICE/REIMBURSEMENT MILEAGE/MEALS CIMPL	337.83
Total 71603:						337.83
71604						
03/23	03/24/2023	71604	CITY OF PEWAUKEE	APRIL 2023	APRIL 2023 FIRE/EMS	170,026.42
Total 71604:						170,026.42
71605						
03/23	03/24/2023	71605	CORE & MAIN LP	S435799	HYDRANT REPLACEMENT MEADOWSIDE CT	5,469.87
03/23	03/24/2023	71605	CORE & MAIN LP	S462427	HYDRANT EXTENSION FOR PARTRIDGE CT	811.19
Total 71605:						6,281.06
71606						
03/23	03/24/2023	71606	DIVERSIFIED BENEFIT S	377157	FLEX BEN ADMIN MAR 2023	155.60
Total 71606:						155.60
71607						
03/23	03/24/2023	71607	ELECTRICAL SERVICES	3834	ANNUAL WEATHER SIREN MAINTENANCE	422.00
Total 71607:						422.00
71608						
03/23	03/24/2023	71608	ELLIOTT'S ACE HARDWA	846420	14# MAGNETIC HOOK	11.98
03/23	03/24/2023	71608	ELLIOTT'S ACE HARDWA	846424	SPRAY PAINT & PRIMER FOR KEY BOX	18.18
03/23	03/24/2023	71608	ELLIOTT'S ACE HARDWA	846430	WALL ANCHORS	6.99
03/23	03/24/2023	71608	ELLIOTT'S ACE HARDWA	846456	WELL 3 VALVE HARDWARE	5.24
03/23	03/24/2023	71608	ELLIOTT'S ACE HARDWA	846480	SHOP AIR LINE REDUCER	4.69
03/23	03/24/2023	71608	ELLIOTT'S ACE HARDWA	846555	SHOP AIR LINE & WATER LINE MISC HARDWARE	46.83
03/23	03/24/2023	71608	ELLIOTT'S ACE HARDWA	846556	SHOP - WATER LINE NOZZLE	39.96
03/23	03/24/2023	71608	ELLIOTT'S ACE HARDWA	846558	WELL 3 OUTLET COVER	.49
03/23	03/24/2023	71608	ELLIOTT'S ACE HARDWA	846572	BLDG WATER LINE NOZZLE & HOSE-HANGER	56.97
03/23	03/24/2023	71608	ELLIOTT'S ACE HARDWA	846574	BLDG WATER LINE HOSE & HANGER RETURN CREDIT	40.98-
03/23	03/24/2023	71608	ELLIOTT'S ACE HARDWA	846575	HANDY HOOK & HOSE FOR BLDG	16.58
03/23	03/24/2023	71608	ELLIOTT'S ACE HARDWA	846584	SHOP AIR LINES FITTING	2.98
03/23	03/24/2023	71608	ELLIOTT'S ACE HARDWA	846601	SHOP AIR LINE FITTING	5.99
03/23	03/24/2023	71608	ELLIOTT'S ACE HARDWA	846609	SHOP- HOSE HOOK	1.59

GL Period	Check Issue Date	Check Number	Payee	Invoice Number	Description	Check Amount
03/23	03/24/2023	71608	ELLIOTT'S ACE HARDWA	846613	SHOP - TAPCON FOR HANGING ITEMS	6.99
03/23	03/24/2023	71608	ELLIOTT'S ACE HARDWA	846616	COLORED PENCILS - UTILITY DRAWINGS	2.99
03/23	03/24/2023	71608	ELLIOTT'S ACE HARDWA	846674	METER SUPPLY	24.94
03/23	03/24/2023	71608	ELLIOTT'S ACE HARDWA	846762	VH - WALL ANCHORS	3.99
03/23	03/24/2023	71608	ELLIOTT'S ACE HARDWA	95+550	MISC HARDWARE FOR HANGING BLDG ITEMS	2.00
Total 71608:						218.40
71609						
03/23	03/24/2023	71609	EWALD'S HARTFORD FO	43396	POLICE/NEW 2023 SQUAD VIN#PGA37198	37,970.00
03/23	03/24/2023	71609	EWALD'S HARTFORD FO	43397	POLICE/NEW 2023 SQUAD VIN#PGA37097	37,970.00
Total 71609:						75,940.00
71610						
03/23	03/24/2023	71610	FORREST, JULIE	03202023	COURT EXPENSE	119.00
Total 71610:						119.00
71611						
03/23	03/24/2023	71611	GRAINGER	9628518715	#127 CARBIDE TAP EXTRACTOR	69.57
Total 71611:						69.57
71612						
03/23	03/24/2023	71612	GREY HOUSE PUBLISHIN	978946	LIBRARY/NON FIC BOOK	148.50
03/23	03/24/2023	71612	GREY HOUSE PUBLISHIN	978947	LIBRARY/ADULT NON-FIC	134.10
Total 71612:						282.60
71613						
03/23	03/24/2023	71613	HAWKINS INC	6404474	HMO	3,377.38
Total 71613:						3,377.38
71614						
03/23	03/24/2023	71614	JANI-KING OF MILWAUKE	MIL03230406	LIBRARY/JANITORIAL SVC MARCH 2023	2,675.91
Total 71614:						2,675.91
71615						
03/23	03/24/2023	71615	KEMPEN MASONRY LLC	7545	LIBRARY/SALT SVC 3.6.23	108.75
Total 71615:						108.75
71616						
03/23	03/24/2023	71616	KEN WEBER TRUCK SER	37472-1	POLICE/ARREST TOW 03-06-2023	164.00
Total 71616:						164.00
71617						
03/23	03/24/2023	71617	LAKE COUNTRY AUTOCA	95093	#639 -REMOVE & REPLACE ALTERNATOR	860.82
Total 71617:						860.82

GL Period	Check Issue Date	Check Number	Payee	Invoice Number	Description	Check Amount
71618						
03/23	03/24/2023	71618	LANNON STONE PRODU	1360558	#1 STONE - HYDRANT REPLACEMENT	323.95
Total 71618:						323.95
71619						
03/23	03/24/2023	71619	LEAGUE OF WISCONSIN	2023 SW ME	2023 STORM GROUP MEMBERSHIP	200.00
Total 71619:						200.00
71620						
03/23	03/24/2023	71620	LENIUS, JEFFREY M	03162023	POLICE/REIMBURSE WORK SHOES-LENIUS	140.00
Total 71620:						140.00
71621						
03/23	03/24/2023	71621	LINCOLN CONTRACTOR	I35452	#135 - WATER SHUT OFF VALVE	44.49
03/23	03/24/2023	71621	LINCOLN CONTRACTOR	I36039	WHITE MARKING PAINT	365.40
Total 71621:						409.89
71622						
03/23	03/24/2023	71622	LINDE GAS & EQUIPMEN	34535374	ACETYLENE & OXYGEN	142.28
Total 71622:						142.28
71623						
03/23	03/24/2023	71623	MEI TOTAL ELEVATOR S	1007635	LIBRARY/QTRLY ELEVATOR SVC/MAR-MAY 2023	337.43
Total 71623:						337.43
71624						
03/23	03/24/2023	71624	MICHALSEN, ERIK	03102023	POLICE/MICHALSEN UNIFORM BOOTS REIMBURSMENT	169.95
Total 71624:						169.95
71625						
03/23	03/24/2023	71625	MIDWEST FIBER NETWO	31034	WATER/INTERNET	150.13
03/23	03/24/2023	71625	MIDWEST FIBER NETWO	31036	SEWER/INTERNET	150.13
Total 71625:						300.26
71626						
03/23	03/24/2023	71626	MIDWEST METER INC	0153484-IN	CELLULAR PROGRAMMING DEVICE	150.00
Total 71626:						150.00
71627						
03/23	03/24/2023	71627	MORAIN DEVELOPMEN	3019467	IMPORTED FILL 03.02.23-HYDRANT REPLACEMENT	134.64
Total 71627:						134.64
71628						
03/23	03/24/2023	71628	NORTH SHORE BANK CA	00669CO2305	LIBRARY/OVERDRIVE/DIGITAL MATERIALS	586.27
03/23	03/24/2023	71628	NORTH SHORE BANK CA	007705202172	LIBRARY/SPECTRUM/PHONE AND INTERNET 2/17/2023-3/16/202	222.94
03/23	03/24/2023	71628	NORTH SHORE BANK CA	02152023	LIBRARY/WI HISTORICAL SOC/FRIENDS EXPLORE PASS	500.00

GL Period	Check Issue Date	Check Number	Payee	Invoice Number	Description	Check Amount
03/23	03/24/2023	71628	NORTH SHORE BANK CA	167	LIBRARY/WAUKESHA FREEMAN/ANNUAL SUBSCRIPTION	264.00
03/23	03/24/2023	71628	NORTH SHORE BANK CA	3361518952	LIBRARY/CSLP/YOUTH SUMMER READING PROGRAM SUPPLIE	180.68
03/23	03/24/2023	71628	NORTH SHORE BANK CA	423505554010	LIBRARY/DOLLAR TREE/YA PROG	3.75
03/23	03/24/2023	71628	NORTH SHORE BANK CA	43940424465	LIBRARY/FRIENDS EXPLORE PASS/BOERNER BOTANICAL GAR	100.00
03/23	03/24/2023	71628	NORTH SHORE BANK CA	4676374741	LIBRARY/GOOGLE/WORKSPACE FEB	6.00
03/23	03/24/2023	71628	NORTH SHORE BANK CA	636109104020	LIBRARY/DOLLAR TREE/YA PROG	11.25
03/23	03/24/2023	71628	NORTH SHORE BANK CA	6863	LIBRARY/CYBERLINK/PHONE SERVICE JAN 2023	348.01
03/23	03/24/2023	71628	NORTH SHORE BANK CA	7059	LIBRARY/CYBERLINK/PHONE SERVICE FEB 2023	348.01
03/23	03/24/2023	71628	NORTH SHORE BANK CA	7269062	LIBRARY/DEMCO/PROCESSING SUPPLIES	172.79
03/23	03/24/2023	71628	NORTH SHORE BANK CA	7269238	LIBRARY/DEMCO/JUV PROGRAM SUPPLIES	141.99
03/23	03/24/2023	71628	NORTH SHORE BANK CA	840553001672	LIBRARY/USPS/STAMPS FOR JUV PROG	9.60
03/23	03/24/2023	71628	NORTH SHORE BANK CA	902004167040	LIBRARY/DOLLAR TREE/YA PROG	6.25
03/23	03/24/2023	71628	NORTH SHORE BANK CA	INV-US-63946	LIBRARY/ENVISIONWARE/BRANCH MANAGER	140.96
Total 71628:						3,042.50
71629						
03/23	03/24/2023	71629	PEWAUKEE SCHOOL DIS	MAR 2023	MOBILE HOME FEES MAR 2023	93.86
Total 71629:						93.86
71630						
03/23	03/24/2023	71630	PROHEALTH CARE LABO	10002537646	POLICE/LEGAL BLOOD DRAW/03/01/2023	37.13
Total 71630:						37.13
71631						
03/23	03/24/2023	71631	R & R INSURANCE SERVI	2805656	LIABILITY INSURANCE	27,454.78
03/23	03/24/2023	71631	R & R INSURANCE SERVI	2805656 - LIB	LIBRARY/INSURANCE LWMMI/CYBER 2ND QUARTER	1,684.72
03/23	03/24/2023	71631	R & R INSURANCE SERVI	2805657	WC 2ND QTR	17,185.27
03/23	03/24/2023	71631	R & R INSURANCE SERVI	2805657 - LIB	LIBRARY/INSURANCE WC 2ND QUARTER	213.73
Total 71631:						46,538.50
71632						
03/23	03/24/2023	71632	RESERVE ACCOUNT - PI	MAR 2023	#27981091 POSTAGE METER REFILL	2,000.00
Total 71632:						2,000.00
71633						
03/23	03/24/2023	71633	RHODE, ADAM	135585052	POLICE/REIMBURSEMENT RHODE FOR WORK SHIRTS	.00 V
03/23	03/24/2023	71633	RHODE, ADAM	WR23007585	POLICE/REIMBURSEMENT RHODE FOR WORK SHIRTS	.00 V
Total 71633:						.00
71634						
03/23	03/24/2023	71634	S-0-S ELECTRONICS CO	2022-12028	DPW SECURITY SYSTEM	17,109.50
Total 71634:						17,109.50
71635						
03/23	03/24/2023	71635	SALEM PRESS INC	184348	LIBRARY/FREIGHT CHARGE	103.74
Total 71635:						103.74

GL Period	Check Issue Date	Check Number	Payee	Invoice Number	Description	Check Amount
71636						
03/23	03/24/2023	71636	SATYANARAYANA KARRI	0874126-2022	2022 TAX REFUND 0874126	77.30
Total 71636:						77.30
71637						
03/23	03/24/2023	71637	SPANKOWSKI, WILLIAM	02192023	POLICE/BOAT PATROL TRAINING SPANKOWSKI- MEAL REIMBU	625.23
Total 71637:						625.23
71638						
03/23	03/24/2023	71638	STREICHERS	1621541	POLICE/UNIFORM/SUPPLIES RHODE FOR SCIT	2,053.71
Total 71638:						2,053.71
71639						
03/23	03/24/2023	71639	STUART STARDY	0902124008-2	2022 TAX REFUND 0902124008	225.78
Total 71639:						225.78
71640						
03/23	03/24/2023	71640	TACTICAL SOLUTIONS	9418	POLICE/RADAR CERTIFICATION FOR SQUADS	389.00
Total 71640:						389.00
71641						
03/23	03/24/2023	71641	TAYLOR COMPUTER SER	24393	LIBRARY/ANNUAL PC REPLACEMENT	4,993.05
03/23	03/24/2023	71641	TAYLOR COMPUTER SER	24397	WIFI SETUP	1,931.00
03/23	03/24/2023	71641	TAYLOR COMPUTER SER	24462	POLICE/MONTHLY IT BILLING 02/01/2023-02/28/2023	172.50
03/23	03/24/2023	71641	TAYLOR COMPUTER SER	24463	NEW BLDG IT SETUP	2,184.60
03/23	03/24/2023	71641	TAYLOR COMPUTER SER	24464	LIBRARY/MANAGED SERVICES FOR MARCH 2023	218.50
Total 71641:						9,499.65
71642						
03/23	03/24/2023	71642	US CELLULAR	0565305079	CELL SERVICE	63.00
03/23	03/24/2023	71642	US CELLULAR	0565659649	POLICE/ CELL PHONES 02/02/2023-03/02/2023	426.74
Total 71642:						489.74
71643						
03/23	03/24/2023	71643	VILLAGE OF HARTLAND	2023 ELECTI	2023 ELECTION NOTICES	40.73
Total 71643:						40.73
71644						
03/23	03/24/2023	71644	WALDEN, NEITZKE & KU	129249	LIBRARY/LEGAL SVCS	1,925.00
Total 71644:						1,925.00
71645						
03/23	03/24/2023	71645	WALMART	X23001422	RESTITUTION	98.48
Total 71645:						98.48

GL Period	Check Issue Date	Check Number	Payee	Invoice Number	Description	Check Amount
71646						
03/23	03/24/2023	71646	WAUKESHA COUNTY TE	S0794634	POLICE/TRAINING, ZABEL, PFEIL, MAYEK, HEIER, FOTH, DRUM	369.61
Total 71646:						369.61
71647						
03/23	03/24/2023	71647	WAUKESHA COUNTY TR	2023-4003001	#639 FULL SERVICE WITH CEHICLE INSPECTION.	717.25
Total 71647:						717.25
71648						
03/23	03/24/2023	71648	WILS	498155	LIBRARY/2023 WPLC BUYING POOL	3,946.00
Total 71648:						3,946.00
71649						
03/23	03/24/2023	71649	WISCONSIN CHIEFS OF	8549	POLICE/2023 MEMBERSHIP DUES	150.00
Total 71649:						150.00
71650						
03/23	03/24/2023	71650	RHODE, ADAM	WR23007585	POLICE/REIMBURSEMENT RHODE FOR WORK SHIRTS	236.21
Total 71650:						236.21
71651						
03/23	03/31/2023	71651	AMAZON CAPITAL SERVI	14K7-Q6FX-3	LIBRARY/MEETING ROOM SUPPLIES	74.44
03/23	03/31/2023	71651	AMAZON CAPITAL SERVI	1FXT-VPW9-K	LIBRARY/CLEANING SUPPLIES MULTI	486.38
03/23	03/31/2023	71651	AMAZON CAPITAL SERVI	1QYL-RJ6C-7	LIBRARY/2 ADULT CDS	27.28
03/23	03/31/2023	71651	AMAZON CAPITAL SERVI	1WL9-M9XQ-1	LIBRARY/CLEANING SUPPLIES MULTIFOLD TOWELS	133.22
03/23	03/31/2023	71651	AMAZON CAPITAL SERVI	1WXC-YLWD-	LIBRARY/MEETING ROOM SUPPLIES	12.99
Total 71651:						734.31
71652						
03/23	03/31/2023	71652	ARAMARK UNIFORM & C	6140138873	SEWER UNIFORMS	176.76
03/23	03/31/2023	71652	ARAMARK UNIFORM & C	6140142447	SEWER UNIFORMS	176.76
03/23	03/31/2023	71652	ARAMARK UNIFORM & C	6140146270	SEWER UNIFORMS	165.67
03/23	03/31/2023	71652	ARAMARK UNIFORM & C	6140149094	MAT EXCHANGE MAR 2023	40.10
03/23	03/31/2023	71652	ARAMARK UNIFORM & C	6140150272	SEWER UNIFORMS	165.67
Total 71652:						724.96
71653						
03/23	03/31/2023	71653	ASSOCIATED APPRAISAL	167675	ASSESSOR/FULL VALUE MAINT-APRIL 2023	3,583.33
Total 71653:						3,583.33
71654						
03/23	03/31/2023	71654	BUILDING SERVICE, INC.	165086	DPW BLDG FURNISHINGS	20,904.21
Total 71654:						20,904.21
71655						
03/23	03/31/2023	71655	INDUSTRIAL MARKETING	44349	#401-WATER VALVE SOLENOID	153.99

GL Period	Check Issue Date	Check Number	Payee	Invoice Number	Description	Check Amount
Total 71655:						153.99
71656						
03/23	03/31/2023	71656	JOHNSON CONTROLS S	38592392	VILLAGE HALL ALARM MONITORING	402.15
Total 71656:						402.15
71657						
03/23	03/31/2023	71657	JULIE FORREST	03272023	PRINTER REIMB FOR ADDTL COST	44.00
03/23	03/31/2023	71657	JULIE FORREST	03302023	SNACKS FOR COURT MEETING 3/30/23	20.47
Total 71657:						64.47
71658						
03/23	03/31/2023	71658	KEMPEN MASONRY LLC	7556	LIBRARY/SALT-PLOW 3.9.23 AND 3.10.23	795.00
Total 71658:						795.00
71659						
03/23	03/31/2023	71659	LEAGUE OF WI MUNICIP	CLM #WM000	EXCESSIVE CLAIM METRO BROKERS 2021	1,000.00
Total 71659:						1,000.00
71660						
03/23	03/31/2023	71660	MENARDS-CAPITAL ONE	314302323027	DPW BLDG-HDMI ADAPTER & CAT6 PATCH CABLE	18.98
03/23	03/31/2023	71660	MENARDS-CAPITAL ONE	314302323075	DPW BLDG-HDMI ADAPTER & CAT6 PATCH CABLE	67.76
03/23	03/31/2023	71660	MENARDS-CAPITAL ONE	314302623031	WHITE OAKS SUMP PUMP	149.00
03/23	03/31/2023	71660	MENARDS-CAPITAL ONE	314303223028	DPW BLDG - CAT6 PATCH CABLE AND ZIP TIES	134.83
03/23	03/31/2023	71660	MENARDS-CAPITAL ONE	314303223028	CAT 6 PATCH CABLE & MISC SCREWS	53.95
03/23	03/31/2023	71660	MENARDS-CAPITAL ONE	314303323032	SAMPLING VALVES-ADAPTERS-TEES	26.61
03/23	03/31/2023	71660	MENARDS-CAPITAL ONE	314303323044	DPW BLDG - HEX SCREWS	26.98
03/23	03/31/2023	71660	MENARDS-CAPITAL ONE	314303323067	DPW BLDG MAG NUT DRIVER & HEX SCREWS	18.96
03/23	03/31/2023	71660	MENARDS-CAPITAL ONE	314303323067	DPW BLDG - HEX SCREWS	7.98
03/23	03/31/2023	71660	MENARDS-CAPITAL ONE	314303723029	DPW BLDG - BINS-ORGANIZERS & SHIMS	162.68
03/23	03/31/2023	71660	MENARDS-CAPITAL ONE	314303823033	DPW BLDG - SCREWS & BIT	27.95
03/23	03/31/2023	71660	MENARDS-CAPITAL ONE	314303923083	DPW BLDG - MISC HARDWARE & SUPPLIES	35.38
03/23	03/31/2023	71660	MENARDS-CAPITAL ONE	314304623068	CEMETERY-LUMBER FORMS FOR FOUNDATIONS	16.70
03/23	03/31/2023	71660	MENARDS-CAPITAL ONE	314305223069	MAILBOX MOUNTING BOARD	5.88
03/23	03/31/2023	71660	MENARDS-CAPITAL ONE	314305823051	PAPER GOODS - PLATES, BOWLS, SPOONS, KNIVES, FORKS	36.37
03/23	03/31/2023	71660	MENARDS-CAPITAL ONE	314305923051	VILLAGE HALL SOFTENER SALT	69.90
03/23	03/31/2023	71660	MENARDS-CAPITAL ONE	314305923061	WELDER PLUG END	15.99
03/23	03/31/2023	71660	MENARDS-CAPITAL ONE	314306023051	#201 CHEATER PIPE-DRIVER-TORCH	105.94
03/23	03/31/2023	71660	MENARDS-CAPITAL ONE	314306523228	RETURN CREDIT - GALVANIZED CHEATER PIPE	39.99-
03/23	03/31/2023	71660	MENARDS-CAPITAL ONE	314306723070	DPW BLDG - SPRAY PAINT	6.98
03/23	03/31/2023	71660	MENARDS-CAPITAL ONE	314306823063	LP TANK EXCHANGE FOR MANHOLE RINGS	59.76
03/23	03/31/2023	71660	MENARDS-CAPITAL ONE	314307223024	BLADES & PIPE	63.99
03/23	03/31/2023	71660	MENARDS-CAPITAL ONE	314307523608	RETURN CREDIT - DPW BLDG-HDMI ADAPTER & CAT6 PATCH C	41.84-
03/23	03/31/2023	71660	MENARDS-CAPITAL ONE	314307523608	RETURN CREDIT - SAMPLING TAP VALVE	7.03-
03/23	03/31/2023	71660	MENARDS-CAPITAL ONE	326103423073	DPW BLDG - BINS & HOOKS	128.64
03/23	03/31/2023	71660	MENARDS-CAPITAL ONE	326103723038	DPW BLDG - ORGANIZERS & BINS	155.84
Total 71660:						1,308.19
71661						
03/23	03/31/2023	71661	NORTH CENTRAL UTILIT	W501408	#303 - NYLON AIR TUBING FOR BOOM	31.50

GL Period	Check Issue Date	Check Number	Payee	Invoice Number	Description	Check Amount
Total 71661:						31.50
71662						
03/23	03/31/2023	71662	NORTHERN LAKE SERVI	2302557	03.07.23 BACTERIA	100.00
Total 71662:						100.00
71663						
03/23	03/31/2023	71663	PEWAUKEE SCHOOL DIS	LOTTERY CR	2022 LOTTERY CREDIT DISTRIBUTION	1,010.50
Total 71663:						1,010.50
71664						
03/23	03/31/2023	71664	POMP'S TIRE SERVICE I	60300954	#119 - (2) TIRES	235.90
Total 71664:						235.90
71665						
03/23	03/31/2023	71665	RA SMITH, INC	171892	OUTSIDE ENG ASSISTANCE - MODEL UPDATE/REVIEW	987.00
03/23	03/31/2023	71665	RA SMITH, INC	171893	RASMITH E WISCONSIN CONSTRUCTION SERVICES	1,757.06
03/23	03/31/2023	71665	RA SMITH, INC	171894	RA SMITH CHARGEBACK - MATTER SENIOR DEV	42.00
03/23	03/31/2023	71665	RA SMITH, INC	171895	RA SMITH CHARGEBACK - PSD SOFTBALL FIELD	1,257.75
03/23	03/31/2023	71665	RA SMITH, INC	171896	RA SMITH CHARGEBAK - MENARDS	84.00
03/23	03/31/2023	71665	RA SMITH, INC	171897	2023 CIP DESIGN	11,908.28
03/23	03/31/2023	71665	RA SMITH, INC	171910	RA SMITH PC	261.17
03/23	03/31/2023	71665	RA SMITH, INC	171911	RA SMITH CHARGEBACK - WCTC BLDG V	924.00
03/23	03/31/2023	71665	RA SMITH, INC	171912	RA SMITH CHARGEBACK - KIRKLAND CROSSING	550.50
Total 71665:						17,771.76
71666						
03/23	03/31/2023	71666	SELZER-ORNST CONSTR	PAY APP #14	DPW BLDG-PAY APP 14	79,747.75
Total 71666:						79,747.75
71667						
03/23	03/31/2023	71667	SOERENS FORD INC	48092	#637 WIPER BLADE ASSEMBLY	68.72
Total 71667:						68.72
71668						
03/23	03/31/2023	71668	STAPLES ADVANTAGE	8069533223	DISINFECTANT	111.61
Total 71668:						111.61
71669						
03/23	03/31/2023	71669	STRAEHLER JR, JACK B	2023 SAFETY	2023 SAFETY GLASSES	385.00
Total 71669:						385.00
71670						
03/23	03/31/2023	71670	WAUKESHA COUNTY TR	2023-2004002	FEBRUARY INMATE BILLING	19.72
Total 71670:						19.72

GL Period	Check Issue Date	Check Number	Payee	Invoice Number	Description	Check Amount
300000042						
03/23	03/03/2023	300000042	ACH DELTA DENTAL OF	1908449	DENTAL INS-MARCH 2023	3,043.58
Total 300000042:						3,043.58
300000043						
03/23	03/03/2023	300000043	ACH WE ENERGIES	4484163521	497 PARK AVE -SEWER-MAPLE LIFT	159.06
Total 300000043:						159.06
300000044						
03/23	03/10/2023	300000044	ACH KWIK TRIP INC - FU	DPW 02-2023	DPW- JAN 2023	3,817.38
03/23	03/10/2023	300000044	ACH KWIK TRIP INC - FU	PD 02-2023	POLICE- JAN 2023	2,093.94
03/23	03/10/2023	300000044	ACH KWIK TRIP INC - FU	SEWER 02-20	SEWER- JAN 2023	401.55
03/23	03/10/2023	300000044	ACH KWIK TRIP INC - FU	WTR 02-2023	WATER- JAN 2023	349.41
Total 300000044:						6,662.28
300000048						
03/23	03/17/2023	300000048	AMAZON CAPITAL SERVI	1LCC-TT6R-V	LIBRARY/JUV PROGRAM SUPPLIES	.00 V
03/23	03/17/2023	300000048	AMAZON CAPITAL SERVI	1PJX-KYYT-T	LIBRARY/OFFICE SUPPLIES	.00 V
03/23	03/17/2023	300000048	AMAZON CAPITAL SERVI	1TFP-7DLG-T	LIBRARY/1 ADULT FIC BK	.00 V
03/23	03/17/2023	300000048	AMAZON CAPITAL SERVI	1VG4-XVN4-T	LIBRARY/JUV PROGRAM SUPPLIES	.00 V
03/23	03/17/2023	300000048	AMAZON CAPITAL SERVI	1WQX-TRYP-	LIBRARY/DISPLAYS	.00 V
Total 300000048:						.00
300000049						
03/23	03/17/2023	300000049	BADGER METER INC	80121713	BEACON HOSTING FEE- FEBRUARY 2444/504 LTE	.00 V
Total 300000049:						.00
300000050						
03/23	03/17/2023	300000050	BAKER & TAYLOR BOOK	2037254928	LIBRARY/PROCESSING	.00 V
03/23	03/17/2023	300000050	BAKER & TAYLOR BOOK	2037289085	LIBRARY/FREIGHT CHARGE	.00 V
03/23	03/17/2023	300000050	BAKER & TAYLOR BOOK	2037295485	LIBRARY/FREIGHT CHARGE	.00 V
03/23	03/17/2023	300000050	BAKER & TAYLOR BOOK	2037301096	LIBRARY/PROCESSING	.00 V
03/23	03/17/2023	300000050	BAKER & TAYLOR BOOK	2037301113	LIBRARY/FREIGHT CHARGE	.00 V
03/23	03/17/2023	300000050	BAKER & TAYLOR BOOK	2037301564	LIBRARY/FREIGHT CHARGE	.00 V
03/23	03/17/2023	300000050	BAKER & TAYLOR BOOK	2037304526	LIBRARY/GIFT ACCT/TRIXIE LAWRENCE MEMORIAL	.00 V
03/23	03/17/2023	300000050	BAKER & TAYLOR BOOK	2037305851	LIBRARY/FREIGHT CHARGE	.00 V
03/23	03/17/2023	300000050	BAKER & TAYLOR BOOK	2037310161	LIBRARY/FREIGHT CHARGE	.00 V
03/23	03/17/2023	300000050	BAKER & TAYLOR BOOK	2037310286	LIBRARY/FREIGHT CHARGE	.00 V
03/23	03/17/2023	300000050	BAKER & TAYLOR BOOK	2037310294	LIBRARY/FREIGHT CHARGE	.00 V
03/23	03/17/2023	300000050	BAKER & TAYLOR BOOK	2037317891	LIBRARY/FREIGHT CHARGE	.00 V
03/23	03/17/2023	300000050	BAKER & TAYLOR BOOK	2037318373	LIBRARY/FREIGHT CHARGE	.00 V
03/23	03/17/2023	300000050	BAKER & TAYLOR BOOK	2037318382	LIBRARY/FREIGHT CHARGE	.00 V
03/23	03/17/2023	300000050	BAKER & TAYLOR BOOK	2037318421	LIBRARY/PROCESSING	.00 V
03/23	03/17/2023	300000050	BAKER & TAYLOR BOOK	2037324506	LIBRARY/FREIGHT CHARGE	.00 V
03/23	03/17/2023	300000050	BAKER & TAYLOR BOOK	2037325908	LIBRARY/FREIGHT CHARGE	.00 V
03/23	03/17/2023	300000050	BAKER & TAYLOR BOOK	2037334179	LIBRARY/FREIGHT CHARGE	.00 V
03/23	03/17/2023	300000050	BAKER & TAYLOR BOOK	2037337372	LIBRARY/FREIGHT CHARGE	.00 V
03/23	03/17/2023	300000050	BAKER & TAYLOR BOOK	2037337641	LIBRARY/FREIGHT CHARGE	.00 V
03/23	03/17/2023	300000050	BAKER & TAYLOR BOOK	2037341010	LIBRARY/FREIGHT CHARGE	.00 V
03/23	03/17/2023	300000050	BAKER & TAYLOR BOOK	2037341127	LIBRARY/FREIGHT CHARGE	.00 V
03/23	03/17/2023	300000050	BAKER & TAYLOR BOOK	2037341391	LIBRARY/FREIGHT CHARGE	.00 V

GL Period	Check Issue Date	Check Number	Payee	Invoice Number	Description	Check Amount
03/23	03/17/2023	300000050	BAKER & TAYLOR BOOK	2037348844	LIBRARY/FREIGHT CHARGE	.00 V
03/23	03/17/2023	300000050	BAKER & TAYLOR BOOK	2037353458	LIBRARY/FREIGHT CHARGE	.00 V
03/23	03/17/2023	300000050	BAKER & TAYLOR BOOK	2037355449	LIBRARY/FREIGHT CHARGE	.00 V
03/23	03/17/2023	300000050	BAKER & TAYLOR BOOK	2037355464	LIBRARY/FREIGHT CHARGE	.00 V
03/23	03/17/2023	300000050	BAKER & TAYLOR BOOK	2037355819	LIBRARY/FREIGHT CHARGE	.00 V
03/23	03/17/2023	300000050	BAKER & TAYLOR BOOK	2037357384	LIBRARY/FREIGHT CHARGE	.00 V
Total 300000050:						.00
300000051						
03/23	03/17/2023	300000051	BLACKSTONE PUBLISHI	2085154	LIBRARY/ADULT 1 AUDIO CD	.00 V
Total 300000051:						.00
300000052						
03/23	03/17/2023	300000052	BURKE TRUCK & EQUIP	31306	MISC PLOW PARTS INCLUDING - CUTTING EDGES, CURB, SHO	.00 V
Total 300000052:						.00
300000053						
03/23	03/17/2023	300000053	BV TETZLAFF	5846	WATER SVC REPAIR 1302 SUNNYRIDGE	.00 V
03/23	03/17/2023	300000053	BV TETZLAFF	5847	WATER MAIN REPAIR 536 HIGH ST	.00 V
Total 300000053:						.00
300000054						
03/23	03/17/2023	300000054	CHAVEZ, LISA	02222023	LIBRARY/REIMBURSE PATRON FOR FOUND ITEM	.00 V
Total 300000054:						.00
300000055						
03/23	03/17/2023	300000055	HIPPENMEYER REILLY B	54191 & 5419	GENERAL COURT LEGAL	.00 V
Total 300000055:						.00
300000056						
03/23	03/17/2023	300000056	HYDROCORP	71171-IN	CROSS CONNECT PRGM FEB 2023	.00 V
Total 300000056:						.00
300000057						
03/23	03/17/2023	300000057	JAMES IMAGING SYSTE	33575939	LIBRARY/MONTHLY COPIER LEASE/MARCH 2023	.00 V
Total 300000057:						.00
300000058						
03/23	03/17/2023	300000058	JF AHERN COMPANY	561334	LIBRARY/FIRE ALARM-FEB ANNUAL 2023	.00 V
Total 300000058:						.00
300000059						
03/23	03/17/2023	300000059	KAESTNER AUTO ELECT	420006	#104 SALTER CONTROL TOGGLE SWITCH & FUSE	.00 V
03/23	03/17/2023	300000059	KAESTNER AUTO ELECT	420007	#104 MAX 30 FUSE	.00 V
Total 300000059:						.00

GL Period	Check Issue Date	Check Number	Payee	Invoice Number	Description	Check Amount
300000060						
03/23	03/17/2023	300000060	KEMPEN MASONRY LLC	7512	LIBRARY/SALT-PLOW 2.16.23	.00 V
03/23	03/17/2023	300000060	KEMPEN MASONRY LLC	7519	LIBRARY/SALT SVC 2.22.23	.00 V
03/23	03/17/2023	300000060	KEMPEN MASONRY LLC	7531	LIBRARY/SALT-PLOW 2.22.23 AND 2.23.23	.00 V
03/23	03/17/2023	300000060	KEMPEN MASONRY LLC	7540	LIBRARY/SALT-PLOW 2.25.23	.00 V
Total 300000060:						.00
300000061						
03/23	03/17/2023	300000061	LAKE COUNTRY AUTOCA	94943	#640 MOUNT AND BALANCE (4) TIRES	.00 V
Total 300000061:						.00
300000062						
03/23	03/17/2023	300000062	MIDWEST TAPE	503320135	LIBRARY/ 1 ADULT CD	.00 V
03/23	03/17/2023	300000062	MIDWEST TAPE	503320137	LIBRARY/1 ADULT DVD	.00 V
03/23	03/17/2023	300000062	MIDWEST TAPE	503320138	LIBRARY/ADULT 4 DVDS	.00 V
03/23	03/17/2023	300000062	MIDWEST TAPE	503320139	LIBRARY/JUVENILE 3 DVD	.00 V
03/23	03/17/2023	300000062	MIDWEST TAPE	503320270	LIBRARY/JUVENILE 2 DVD	.00 V
03/23	03/17/2023	300000062	MIDWEST TAPE	503411723	LIBRARY/ADULT 2 DVDS	.00 V
03/23	03/17/2023	300000062	MIDWEST TAPE	503411724	LIBRARY/1 ADULT DVD	.00 V
03/23	03/17/2023	300000062	MIDWEST TAPE	503411725	LIBRARY/ 2 ADULT CDS	.00 V
03/23	03/17/2023	300000062	MIDWEST TAPE	503411727	LIBRARY/ADULT 3 DVDS	.00 V
03/23	03/17/2023	300000062	MIDWEST TAPE	503411728	LIBRARY/ 1 JUV CD	.00 V
Total 300000062:						.00
300000063						
03/23	03/17/2023	300000063	MIDWEST TAPE - HOOPL	503441134	LIBRARY/DIGITAL ACCT ENDING 2/28/23	.00 V
Total 300000063:						.00
300000064						
03/23	03/17/2023	300000064	MISSION COMMUNICATI	1073605	LK LEVL SVC 03.01.23 TO 02.29.24 - CHARGEBACK 50% TO LPS	.00 V
Total 300000064:						.00
300000065						
03/23	03/17/2023	300000065	PEWAUKEE SCHOOL DIS	FEB 2023	MOBILE HOME FEES FEB 2023	.00 V
03/23	03/17/2023	300000065	PEWAUKEE SCHOOL DIS	JAN 2023	MOBILE HOME FEES JAN 2023	.00 V
Total 300000065:						.00
300000066						
03/23	03/17/2023	300000066	POMP'S TIRE SERVICE I	60299958	#640/4 TIRES	.00 V
Total 300000066:						.00
300000067						
03/23	03/17/2023	300000067	PROVEN POWER, INC	01-421340	#116 - RIGHT REAR SIDE LIGHT	.00 V
Total 300000067:						.00
300000068						
03/23	03/17/2023	300000068	RUEKERT & MIELKE, INC	145548	SCADA OPERATOR 10 INSTALL	.00 V
03/23	03/17/2023	300000068	RUEKERT & MIELKE, INC	145549	KOPMEIER LIFT STATION DESIGN	.00 V

GL Period	Check Issue Date	Check Number	Payee	Invoice Number	Description	Check Amount	
03/23	03/17/2023	300000068	RUEKERT & MIELKE, INC	145550	WELL 4 HMO DESIGN PILOT TEST	.00	V
03/23	03/17/2023	300000068	RUEKERT & MIELKE, INC	145551	WELL 4 HMO DESIGN	.00	V
Total 300000068:						.00	
300000069							
03/23	03/17/2023	300000069	SHRED-IT USA	8003405498	POLICE/PAPER SHRED 02-22-2023	.00	V
Total 300000069:						.00	
300000070							
03/23	03/17/2023	300000070	SOERENS FORD INC	47884	#645-FLEX TUBE ASY	.00	V
Total 300000070:						.00	
300000071							
03/23	03/17/2023	300000071	TAYLOR COMPUTER SER	24392	LIBRARY/NEW PC AND INSTALLATION	.00	V
03/23	03/17/2023	300000071	TAYLOR COMPUTER SER	24396	DPW WORKSTATION	.00	V
Total 300000071:						.00	
300000072							
03/23	03/17/2023	300000072	WASTE MANAGEMENT	0460390-4163	SOLID WASTE REFUSE	.00	V
Total 300000072:						.00	
300000073							
03/23	03/17/2023	300000073	WAUKESHA LIME AND ST	1850154	COLD PATCH FOR HIGH ST & CHESHIRE MAIN BREAK	.00	V
Total 300000073:						.00	
300000074							
03/23	03/17/2023	300000074	WISCONSIN STATE LABO	736869	FLOURIDE TEST 02.09.23	.00	V
Total 300000074:						.00	
300000075							
03/23	03/30/2023	300000075	ACH WE ENERGIES	4501363608	LIBRARY/GAS SERVICE 2/06-3/06/2023	3,748.08	
Total 300000075:						3,748.08	
300000076							
03/23	03/01/2023	300000076	ACH NORTH SHORE BAN	0553262577A	US CELLULAR/CELL PHONE ADMINISTRATOR	26.14	
03/23	03/01/2023	300000076	ACH NORTH SHORE BAN	0553262577B	US CELLULAR/CELL PHONE CLERKS OFFICE	56.81	
03/23	03/01/2023	300000076	ACH NORTH SHORE BAN	0553262577C	US CELLULAR/CELL PHONE DPW	196.45	
03/23	03/01/2023	300000076	ACH NORTH SHORE BAN	0553262577D	US CELLULAR/CELL PHONE WATER	117.95	
03/23	03/01/2023	300000076	ACH NORTH SHORE BAN	0553262577E	US CELLULAR/CELL PHONE SEWER	87.11	
03/23	03/01/2023	300000076	ACH NORTH SHORE BAN	10331870	RIVEREDGE NATURE/CHAIN SAW TRAINING LUICK	65.00	
03/23	03/01/2023	300000076	ACH NORTH SHORE BAN	1042023	AMAZON/POLICE/BANKER BOXES	126.58	
03/23	03/01/2023	300000076	ACH NORTH SHORE BAN	1112023	AMAZON/POLICE/OFFICE SUPPLIES PENS	77.29	
03/23	03/01/2023	300000076	ACH NORTH SHORE BAN	112-3456583-8	AMAZON/SOLAR FENCE LIGHTS	38.49	
03/23	03/01/2023	300000076	ACH NORTH SHORE BAN	112-4080863-1	AMAZON/MAGNETS	12.98	
03/23	03/01/2023	300000076	ACH NORTH SHORE BAN	112-4080863-1	AMAZON/WALL FILE & W2 FORMS	89.88	
03/23	03/01/2023	300000076	ACH NORTH SHORE BAN	112-4995571-2	AMAZON/J PETER NOTARY STAMP	22.89	
03/23	03/01/2023	300000076	ACH NORTH SHORE BAN	113-0703508-2	AMAZON/PLATFORM CARTS	431.98	
03/23	03/01/2023	300000076	ACH NORTH SHORE BAN	113-0952603-2	AMAZON/VACUUM CLEANING EQUIPMENT	149.95	

GL Period	Check Issue Date	Check Number	Payee	Invoice Number	Description	Check Amount
03/23	03/01/2023	300000076	ACH NORTH SHORE BAN	113-1523280-3	AMAZON/GARBAGE BAGS	54.83
03/23	03/01/2023	300000076	ACH NORTH SHORE BAN	113-1807890-4	AMAZON/CLEANING SUPPLIES	36.43
03/23	03/01/2023	300000076	ACH NORTH SHORE BAN	113-3015530-7	AMAZON/SUPPLIES/PAPER	119.98
03/23	03/01/2023	300000076	ACH NORTH SHORE BAN	113-4075356-8	AMAZON/FEDERAL LABOR POSTER	17.95
03/23	03/01/2023	300000076	ACH NORTH SHORE BAN	113-4900891-8	AMAZON/LABELS/TAPE	79.12
03/23	03/01/2023	300000076	ACH NORTH SHORE BAN	113-7426775-1	AMAZON/POLICE/OFFICE SUPPLIES	26.27
03/23	03/01/2023	300000076	ACH NORTH SHORE BAN	113-7472774-5	AMAZON/POLICE/NEW "COPY" STAMPER	8.85
03/23	03/01/2023	300000076	ACH NORTH SHORE BAN	1182023	AMAZON/POLICE/USB FLASH DRIVES & SD CARDS	76.81
03/23	03/01/2023	300000076	ACH NORTH SHORE BAN	1192023	AMAZON/POLICE/DRY BOXES FOR NARCAN	30.97
03/23	03/01/2023	300000076	ACH NORTH SHORE BAN	186993348	ZOOM/MONTHLY SUBSCRIPTION	13.38
03/23	03/01/2023	300000076	ACH NORTH SHORE BAN	2012023	MILW JOURNAL/POLICE ONLINE SUBS CHIEF	7.99
03/23	03/01/2023	300000076	ACH NORTH SHORE BAN	2023 CLERK	LOCAL GOVT EDU/J PETER CLERK & TREASR TRNG	499.00
03/23	03/01/2023	300000076	ACH NORTH SHORE BAN	2023 RENEW	WI MUNI CLERKS/J PETER 2023 MEMBERSHIP	65.00
03/23	03/01/2023	300000076	ACH NORTH SHORE BAN	213907194	LEAGE OF WI MUNI/C SMITH HR CLASSS	75.00
03/23	03/01/2023	300000076	ACH NORTH SHORE BAN	22035	CLEAR CUT PRINT/COURT SUPPLIES	233.00
03/23	03/01/2023	300000076	ACH NORTH SHORE BAN	24355	AXON/POLICE TASER BATTERY PACKS	396.15
03/23	03/01/2023	300000076	ACH NORTH SHORE BAN	315294	USPS/ADD'L ELECTION POSTAGE	.60
03/23	03/01/2023	300000076	ACH NORTH SHORE BAN	3639 1102023	FARM & FLEET/2 HAND TRUCKS	429.98
03/23	03/01/2023	300000076	ACH NORTH SHORE BAN	513291	USPS/ADD'L ELECTION POSTAGE	3.90
03/23	03/01/2023	300000076	ACH NORTH SHORE BAN	CM RETURN	AMAZON/RETURN MONTHLY PLANNER	13.93-
03/23	03/01/2023	300000076	ACH NORTH SHORE BAN	CYREMAS	DOJ/OPERATOR CHECKS	7.00
03/23	03/01/2023	300000076	ACH NORTH SHORE BAN	HGBVKTHC	DOJ/OPERATOR CHECKS	7.00
03/23	03/01/2023	300000076	ACH NORTH SHORE BAN	JAN 2023-1	BESTBUY/WALMART/NEW BLDG OFFICE SUPPLIES	1,288.66
03/23	03/01/2023	300000076	ACH NORTH SHORE BAN	JAN 2023-2	BESTBUY/WALMART/NEW BLDG OFFICE SUPPLIES	402.71
03/23	03/01/2023	300000076	ACH NORTH SHORE BAN	JAN 2023-3	BESTBUY/WALMART/NEW BLDG OFFICE SUPPLIES	322.17
03/23	03/01/2023	300000076	ACH NORTH SHORE BAN	JAN 2023-4	AMAZON/VACUUM & PAPER	63.39
03/23	03/01/2023	300000076	ACH NORTH SHORE BAN	NZD3MPNB	DOJ/OPERATOR CHECKS	35.00
Total 300000076:						5,786.71
300000077						
03/23	03/24/2023	300000077	ACH DELTA DENTAL OF	1923998	DENTAL INS-APRIL 2023	2,964.57
Total 300000077:						2,964.57
300000078						
03/23	03/24/2023	300000078	ACH WI DEPT OF REVEN	2023 TID ADM	TID 4 DOR ADMIN FEE 2023 GEN FUND ADVANCE	450.00
Total 300000078:						450.00
300000079						
03/23	03/31/2023	300000079	ACH RHYME BUSINESS	33630943	COPIES & LEASE 02.09 TO 03.08.23	523.42
Total 300000079:						523.42
300000080						
03/23	03/31/2023	300000080	ACH WE ENERGIES	4483461752	235 HICKORY ST -STREET LIGHT CLASS C & D ELEC	209.53
03/23	03/31/2023	300000080	ACH WE ENERGIES	4484014249	1110 LAKE PARK DR -LIGHTING	35.96
Total 300000080:						245.49
Grand Totals:						1,408,399.

Summary by General Ledger Account Number

GL Account	Debit	Credit	Proof
110-00-17110-000-000	2,000.00	.00	2,000.00
110-00-21337-000-100	6,008.15	.00	6,008.15
110-00-21337-000-300	5,316.88	.00	5,316.88
110-00-21337-000-400	1,142.39	.00	1,142.39
110-00-21400-000-000	37,468.06	688,751.63-	651,283.57-
110-00-21400-000-999	303.08	.00	303.08
110-00-21761-000-000	1,479.80	187.72-	1,292.08
110-00-45100-000-000	7,478.91	.00	7,478.91
110-00-51120-000-000	261.17	.00	261.17
110-00-51120-000-100	23,071.43	940.00-	22,131.43
110-00-51200-000-140	469.29	.00	469.29
110-00-51300-000-000	5,880.00	2,940.00-	2,940.00
110-00-51300-000-110	4,686.00	2,343.00-	2,343.00
110-00-51320-000-000	76.50	.00	76.50
110-00-51400-000-140	26.14	.00	26.14
110-00-51420-000-140	1,334.07	13.93-	1,320.14
110-00-51440-000-000	71.92	.00	71.92
110-00-51460-000-000	161.54	.00	161.54
110-00-51600-000-310	2,246.81	.00	2,246.81
110-00-51938-000-000	30,810.79	.00	30,810.79
110-00-51980-000-000	155.60	.00	155.60
110-00-52100-000-140	402.00	.00	402.00
110-00-52100-000-310	6,047.37	820.82-	5,226.55
110-00-52100-000-320	358.04	62.97-	295.07
110-00-52100-000-330	887.47	.00	887.47
110-00-52100-000-340	357.99	650.00-	292.01-
110-00-52100-000-350	857.44	.00	857.44
110-00-52100-000-380	2,352.26	.00	2,352.26
110-00-52100-000-400	3,417.64	536.21-	2,881.43
110-00-52200-000-000	406,309.50	.00	406,309.50
110-00-53100-000-140	1,284.62	624.31-	660.31
110-00-53310-000-310	75.06	.00	75.06
110-00-53310-000-311	4,661.86	82.82-	4,579.04
110-00-53330-000-310	10,956.89	2,180.91-	8,775.98
110-00-53340-000-310	5.88	.00	5.88
110-00-53420-000-310	245.49	.00	245.49
110-00-53620-000-000	39,683.98	19,841.99-	19,841.99
110-00-53635-000-000	12,486.76	6,243.38-	6,243.38
110-00-55200-000-000	49,738.50	.00	49,738.50
110-00-55300-000-000	54,031.26	.00	54,031.26
110-00-56600-000-000	65.00	.00	65.00
110-00-57210-000-000	396.15	.00	396.15
110-00-59900-000-000	1,150.00	.00	1,150.00
200-00-21400-000-000	1,464.72	92,472.14-	91,007.42-
200-00-53300-000-100	9,753.78	.00	9,753.78
200-00-53300-000-200	182.55	.00	182.55
200-00-57324-003-000	82,535.81	1,464.72-	81,071.09
450-00-21400-000-000	.00	35,695.00-	35,695.00-
450-00-51580-000-000	150.00	.00	150.00
450-00-51900-000-100	35,545.00	.00	35,545.00
455-00-21400-000-000	.00	36,950.00-	36,950.00-
455-00-51580-000-000	36,950.00	.00	36,950.00
510-00-21400-000-000	.00	90,606.66-	90,606.66-
510-00-51000-000-000	90,606.66	.00	90,606.66
600-00-21400-000-000	14,599.30	163,228.11-	148,628.81-
600-00-50605-002-000	504.01	.00	504.01
600-00-50605-004-000	931.50	465.75-	465.75

GL Account	Debit	Credit	Proof
600-00-50625-002-000	.49	.00	.49
600-00-50630-003-000	5,613.20	28.00-	5,585.20
600-00-50630-004-000	26.61	7.03-	19.58
600-00-50631-002-000	1,910.54	.00	1,910.54
600-00-50631-003-000	5,913.31	.00	5,913.31
600-00-50631-005-000	1,439.51	.00	1,439.51
600-00-50641-001-000	224.52	.00	224.52
600-00-50651-002-000	2,020.91	843.20-	1,177.71
600-00-50652-002-000	1,321.69	320.85-	1,000.84
600-00-50652-006-000	16,250.00	8,125.00-	8,125.00
600-00-50653-002-000	190.69	.00	190.69
600-00-50653-003-000	840.00	.00	840.00
600-00-50653-005-000	104,298.50	.00	104,298.50
600-00-50654-002-000	7,101.11	.00	7,101.11
600-00-50700-001-000	349.41	.00	349.41
600-00-50700-003-000	181.94	39.99-	141.95
600-00-50903-004-000	546.32	273.16-	273.16
600-00-50904-001-000	277.26	.00	277.26
600-00-50921-001-000	2.99	.00	2.99
600-00-50921-003-000	1,248.64	624.32-	624.32
600-00-50923-002-000	3,470.00	1,735.00-	1,735.00
600-00-50923-003-000	4,274.00	2,137.00-	2,137.00
600-00-50923-005-000	146.16	.00	146.16
600-00-50924-000-000	3,298.29	.00	3,298.29
600-00-50931-001-000	846.51	.00	846.51
650-00-21400-000-000	347.40	4,289.38-	3,941.98-
650-00-51938-000-000	2,287.51	.00	2,287.51
650-00-53100-000-140	200.00	.00	200.00
650-00-53330-000-310	229.99	.00	229.99
650-00-53330-100-310	770.80	347.40-	423.40
650-00-53440-000-310	73.08	.00	73.08
650-00-57325-000-000	728.00	.00	728.00
675-00-10367-000-000	19,745.95	.00	19,745.95
675-00-21400-000-000	207.70	27,877.51-	27,669.81-
675-00-53100-000-120	987.00	.00	987.00
675-00-53310-100-310	561.56	207.70-	353.86
675-00-53470-000-310	6,583.00	.00	6,583.00
700-00-10367-000-000	24,682.42	.00	24,682.42
700-00-21400-000-000	11,741.23	294,991.41-	283,250.18-
700-00-50821-000-000	834.15	.00	834.15
700-00-50822-002-000	4,501.75	.00	4,501.75
700-00-50822-003-000	1,150.44	.00	1,150.44
700-00-50822-005-000	385.40	.00	385.40
700-00-50822-010-000	283.45	.00	283.45
700-00-50831-006-000	107.50	.00	107.50
700-00-50832-002-000	149.00	.00	149.00
700-00-50832-003-000	310.50	155.25-	155.25
700-00-50835-001-000	59.76	.00	59.76
700-00-50835-002-000	477.55	.00	477.55
700-00-50836-000-000	277.26	.00	277.26
700-00-50851-004-000	1,794.96	897.48-	897.48
700-00-50852-001-000	21,377.00	10,688.50-	10,688.50
700-00-50853-000-000	7,840.90	.00	7,840.90
700-00-50857-000-000	148,975.82	.00	148,975.82
700-00-50990-000-000	81,783.55	.00	81,783.55
800-00-21400-000-000	.00	16.70-	16.70-
800-00-54920-000-000	16.70	.00	16.70

GL Account	Debit	Credit	Proof
900-00-21400-000-000	11,184.52	49,465.74-	38,281.22-
900-00-48500-000-100	32.00	16.00-	16.00
900-00-55110-000-140	264.00	.00	264.00
900-00-55110-000-141	10,408.48	4,886.35-	5,522.13
900-00-55110-000-142	1,354.45	361.30-	993.15
900-00-55110-000-143	8,216.67	1,429.08-	6,787.59
900-00-55110-000-144	3,173.02	1,010.81-	2,162.21
900-00-55110-000-150	1,898.45	.00	1,898.45
900-00-55110-000-310	10,686.10	2,876.25-	7,809.85
900-00-55110-000-311	4,667.04	.00	4,667.04
900-00-55110-000-312	5,486.67	477.20-	5,009.47
900-00-55110-000-313	544.90	113.39-	431.51
900-00-55110-000-400	1,925.00	.00	1,925.00
900-00-55110-000-500	808.96	14.14-	794.82
950-00-21400-000-000	.00	1,027.79-	1,027.79-
950-00-51938-000-000	402.56	.00	402.56
950-00-52100-000-145	625.23	.00	625.23
960-00-21400-000-000	40.00	80.00-	40.00-
960-00-55200-000-155	80.00	40.00-	40.00
Grand Totals:	1,562,505.00	1,562,505.00-	.00

Report Criteria:

Report type: Invoice detail
 Check.Type = {<>} "Adjustment"

VILLAGE OF PEWAUKEE

BALANCE SHEET

MARCH 31, 2023

FUND 110 - GENERAL FUND

ASSETS

110-00-10155-000-000	CASH CLEARING ACCOUNT	3,517.29	
110-00-11100-000-000	VILLAGE/PD DRAWER CASH	650.00	
110-00-11101-000-000	GENERAL FUND CASH-NORTH SHORE	(1,398,030.97)	
110-00-12000-000-000	ACCOUNTS RECEIVABLE	96,402.87	
110-00-12001-000-000	ACCTS RECEIVABLE- YEAR END	(3,430.87)	
110-00-12100-000-000	TAXES RECEIVABLE	3,864,326.55	
110-00-12201-001-000	CUST ACCTS RECEIVABLE-REFUSE	12,433.76	
110-00-14000-000-000	DUE FROM OTHER GOVERNMENTS	101,267.37	
110-00-16205-000-000	GENERAL FUND SAVINGS-LGIP #1	7,699,679.96	
110-00-16207-000-000	PERPETUAL CARE SAVINGS	68.83	
110-00-16330-000-000	DELINQUENT PERSONAL PROPERTY	(12,623.39)	
110-00-17110-000-000	PREPAID POSTAGE	2,926.39	
	TOTAL ASSETS		10,367,187.79

LIABILITIES AND EQUITY

LIABILITIES

110-00-21331-000-000	SOCIAL SECURITY WITHHOLDING	(34.65)	
110-00-21337-000-000	WIS RETIREMENT SYSTEM PAYABLE	.04	
110-00-21337-000-100	DENTAL WITHHOLDING PAYABLE	1,319.61	
110-00-21337-000-200	HEALTH INS WITHHOLDING PAYABLE	(52,424.88)	
110-00-21400-000-100	FLEX BENEFITS PAYABLE	874.84	
110-00-21400-000-200	BANK FEES DUE NORTH SHORE	1,351.50	
110-00-21401-000-500	DEFERRED REVENUE-OTHER	(38,231.75)	
110-00-21700-000-000	DUE OTHER TAXING DISTRICTS	2,907,975.90	
110-00-21710-000-000	DEFERRED REVENUE	2,158,011.07	
110-00-21761-000-000	MOBILE HOME FEES DUE SCHOOL	(93.86)	
110-00-22100-000-000	DEPOSITS- OTHER	7,150.00	
110-00-22105-000-000	ROW PERMIT DEPOSITS	18,000.00	
	TOTAL LIABILITIES		5,003,897.82

FUND EQUITY

110-00-23501-000-200	DEPOSITS - POLICE MOTORCYCLE	246.42	
110-00-23502-000-000	DEPOSITS - JT PISTOL RANGE	4,124.40	
110-00-23503-000-000	DEPOSITS - LIBRARY BLDG FUND	8,817.29	
110-00-23504-000-000	DEPOSITS - PD ASSET FORFEITURE	449.49	
110-00-23507-000-000	DEPOSITS - OPEN SPACES	1,330.81	
110-00-23512-000-000	DEPOSITS - HARKEN OBSERVATORY	2,529.57	
110-00-31101-000-000	GENERAL FUND BALANCE	2,176,705.94	
110-00-31104-000-000	PD COM RELATION/EVENTS	1,850.00	
110-00-31122-000-000	RESERVED FOR DELINQ PP TAXES	835.00	
110-00-31123-000-000	RESERVED FOR PREPAIDS	84,135.00	
110-00-31124-000-000	RESERVED FOR PK & REC EQUIP	77,730.00	
110-00-31125-000-000	RESERVED FOR KOEPP PARK MAINT	3,364.00	
110-00-31140-000-000	ASSIGNED FOR INFRASTRUCTURE	1,036,831.00	

VILLAGE OF PEWAUKEE
BALANCE SHEET
MARCH 31, 2023

FUND 110 - GENERAL FUND

REVENUES OVER EXPENDITURES - YTD	<u>1,964,341.05</u>	
TOTAL FUND EQUITY		<u>5,363,289.97</u>
TOTAL LIABILITIES & EQUITY		<u><u>10,367,187.79</u></u>

VILLAGE OF PEWAUKEE

COMBINED CASH

MARCH 31, 2023

COMBINED CASH ACCOUNTS

001-00-11000-000-000	POOLED CASH - GENERAL CHECKING	1,293,298.97
001-00-11001-000-000	LGIP	15,441,384.95
	TOTAL COMBINED CASH	16,734,683.92
001-00-11005-000-000	UTILITY CASH CLEARING	(21,728.56)
001-00-11006-000-000	AR CASH CLEARING	(107,098.18)
001-00-11101-000-000	CASH ALLOCATED TO OTHER FUNDS	(16,605,857.18)
	TOTAL UNALLOCATED CASH	.00

CASH ALLOCATION RECONCILIATION

110	ALLOCATION TO GENERAL FUND	(1,398,030.97)
200	ALLOCATION TO CAPITAL PROJECTS FUND	1,281,179.34
300	ALLOCATION TO DEBT SERVICE FUND	77,648.42
450	ALLOCATION TO TIF 2 FUND	216,873.76
455	ALLOCATION TO TIF 3 FUND	117,066.67
500	ALLOCATION TO DOWNTOWN LOAN FUND	5,038.55
510	ALLOCATION TO ARPA FUND	(133,165.55)
600	ALLOCATION TO WATER UTILITY FUND	232,115.39
650	ALLOCATION TO STORMWATER FUND	(147,342.05)
675	ALLOCATION TO TRANSPORTATION FUND	380,978.62
700	ALLOCATION TO SANITARY SEWER FUND	209,651.56
800	ALLOCATION TO CEMETERY FUND	63,735.02
900	ALLOCATION TO LIBRARY FUND	331,254.17
950	ALLOCATION TO LAKE PATROL FUND	40,191.83
960	ALLOCATION TO LAIMON LAKESIDE PARK FUND	1,650.69

RESTRICTED CASH

110-00-16205-000-000	GENERAL FUND SAVINGS-LGIP #1	7,699,679.96
200-00-16500-000-000	LGIP#2 CAPITAL EXPENDITURE SVG	464,066.83
300-00-16552-000-000	UNSPENT LIBRARY LGIP FUNDS	156,711.00
450-00-16205-000-006	GENERAL FUND SAVINGS-LGIP #6	145,758.78
510-00-16205-000-000	GENERAL FUND SAVINGS-LGIP #1	849,175.98
600-00-10113-000-000	WI STATE POOL FD-WATER INVEST	560,380.90
600-00-10113-012-000	WI STATE PL FD-WATER HOOK-UPS	250,003.00
700-00-10113-000-000	LGIP- SEWER INVESTMENTS	1,121,016.48
700-00-10113-003-000	SEWER REPLACE LIFT #1	529,604.02
700-00-10113-003-100	LGIP- SEWER DEBT REPLACEMENT	1,750,255.00
700-00-10113-009-000	LGIP- -SEWER HOOKUPS	1,728,123.45
800-00-11112-000-000	LGIP #8-CEMETARY	32,907.55
960-00-10113-000-700	LAIMON PARK LGIP #7	39,328.78

	TOTAL ALLOCATIONS TO OTHER FUNDS	16,605,857.18
	ALLOCATION FROM COMBINED CASH FUND 001-00-11101-000-0	(16,605,857.18)

ZERO PROOF IF ALLOCATIONS BALANCE .00

VILLAGE OF PEWAUKEE
COMBINED CASH
MARCH 31, 2023

VILLAGE OF PEWAUKEE
FUND SUMMARY
FOR THE 3 MONTHS ENDING MARCH 31, 2023

GENERAL FUND

	PERIOD ACTUAL	YTD ACTUAL	BUDGET	VARIANCE	PCNT
<u>REVENUE</u>					
TAX AND TAX EQUIVALENTS	1,092.11	3,185,052.42	4,379,086.82	1,194,034.40	72.7
SPECIAL ASSESSMENTS	.00	2,500.00	2,000.00	(500.00)	125.0
INTERGOVERNMENTAL AID	.00	92,187.79	689,841.00	597,653.21	13.4
LICENSES AND PERMITS	22,279.26	76,557.77	262,000.00	185,442.23	29.2
FINES AND FORFEITURES	12,410.14	53,619.24	180,000.00	126,380.76	29.8
PUBLIC CHARGES FOR SERVICE	47,730.64	165,505.14	728,358.00	562,852.86	22.7
INTERGOVERNMENTAL AID	.00	88,024.00	572,372.01	484,348.01	15.4
MISCELLANEOUS REVENUES	32,576.87	132,813.27	108,092.00	(24,721.27)	122.9
OTHER SOURCES	.00	32,605.00	130,420.00	97,815.00	25.0
	<u>116,089.02</u>	<u>3,828,864.63</u>	<u>7,052,169.83</u>	<u>3,223,305.20</u>	<u>54.3</u>
<u>EXPENDITURES</u>					
VILLAGE BOARD	2,583.63	7,750.89	31,503.00	23,752.11	24.6
PLANNING/ENG CONSULTING SERV	22,392.60	6,993.42	11,244.00	4,250.58	62.2
MUNICIPAL COURT EXPENSES	5,074.58	19,994.22	62,402.50	42,408.28	32.0
SPECIAL LEGAL	5,283.00	15,745.50	79,000.00	63,254.50	19.9
LABOR ATTORNEY	76.50	1,989.50	10,000.00	8,010.50	19.9
VILLAGE ADMINISTRATOR	13,925.29	29,967.09	123,340.00	93,372.91	24.3
CLERK'S OFFICE EXPENSES	21,032.87	42,695.45	192,711.00	150,015.55	22.2
ELECTIONS	2,484.38	7,577.05	16,800.00	9,222.95	45.1
COPY MACHINE	161.54	469.41	2,300.00	1,830.59	20.4
PUBLICATION EXPENSES	.00	81.52	2,000.00	1,918.48	4.1
AUDIT COSTS	.00	198.60	.00	(198.60)	.0
DATA PROCESSING	.00	7,530.20	14,000.00	6,469.80	53.8
REVALUATION	.00	3,583.37	2,000.00	(1,583.37)	179.2
IMP #1/PURCH ST MARY'S PROPRTY	4,712.31	22,783.73	64,200.00	41,416.27	35.5
OTHER PROPERTY MAINTENANCE	.00	70.46	2,700.00	2,629.54	2.6
INSURANCE EXP-VEH/BLDG/WC/LIAB	61,622.58	88,653.75	170,000.00	81,346.25	52.2
WELLNESS INCENTIVE BENEFIT	.00	.00	200.00	200.00	.0
GENERAL GOVT. MISC. EXPENSES	555.95	1,638.43	3,150.00	1,511.57	52.0
POLICE- NATIONAL NIGHT OUT	258,972.07	567,944.59	2,762,708.06	2,194,763.47	20.6
FIRE ADMINISTRATIVE EXPENSES	406,309.50	541,746.00	1,625,238.00	1,083,492.00	33.3
BUILDING INSPECTION EXPENSES	10,099.19	32,292.60	116,129.00	83,836.40	27.8
ADMINISTRATION EXPENSES	8,462.05	21,044.64	58,737.00	37,692.36	35.8
STREET MAIN. GEN. OPERATION	4,654.10	16,485.67	62,560.00	46,074.33	26.4
FRINGE BENEFITS	52,988.11	115,624.28	438,369.00	322,744.72	26.4
EQUIP MAINT/GENERAL OPERATIONS	8,655.98	19,362.86	68,000.00	48,637.14	28.5
SNOW, ICE CONT. GEN. OPERATION	5.88	5.88	63,500.00	63,494.12	.0
STREET LIGHTING, GEN. OPERAT.	5,022.13	16,878.93	67,500.00	50,621.07	25.0
REFUSE COLLECTION CONTRACT	19,841.99	41,083.31	216,000.00	174,916.69	19.0
RECYCLING EXPENSES	6,243.38	13,089.70	82,000.00	68,910.30	16.0
WEED & NUISANCE CONTROL	.00	.00	1,800.00	1,800.00	.0
OTHER SANITATION	.00	.00	600.00	600.00	.0
ANIMAL CONTROL	.00	4,043.00	4,043.00	.00	100.0
LIBRARY-PROGRAMS	21,895.33	65,686.03	262,744.00	197,057.97	25.0
PARKS	49,738.50	69,041.17	198,954.00	129,912.83	34.7
REC PROGRAMS	54,031.26	72,041.68	216,125.00	144,083.32	33.3

VILLAGE OF PEWAUKEE
 FUND SUMMARY
 FOR THE 3 MONTHS ENDING MARCH 31, 2023

GENERAL FUND

	PERIOD ACTUAL	YTD ACTUAL	BUDGET	VARIANCE	PCNT
URBAN DEVELOPMENT	65.00	5,117.00	18,000.00	12,883.00	28.4
POLICE OUTLAY	396.15	4,163.65	.00	(4,163.65)	.0
CONTINGENCY	1,150.00	1,150.00	.00	(1,150.00)	.0
	<u>1,048,435.85</u>	<u>1,864,523.58</u>	<u>7,050,557.56</u>	<u>5,186,033.98</u>	<u>26.5</u>
	<u>(932,346.83)</u>	<u>1,964,341.05</u>	<u>1,612.27</u>	<u>(1,962,728.78)</u>	<u>12183</u>